

**MOTEC**<sup>®</sup>  
Product Family

# Intelligent DC Servo System

Standard Version



# MOTEC<sup>®</sup>

## *Intelligent DC Servo System*

MOTEC(China) Group consists with four high-tech companies and ten regional sales&marketing companies dedicated to four major industrial fields as below

- 1、 MOTEC DC/AC intelligent stepper system and intelligent servo system
  - 1.1 MOTEC AC intelligent servo driver is an innovated product which integrated traditional servo driver, motion controller and PLC. It allow users to build up reliable motion control system easily with its integrated LadderLogic programming function. All MOTEC AC intelligent servo drivers are CE and ROHS compliant.
  - 1.2 MOTEC DC intelligent servo system provides wide range motor selection from 12.5VDC to 180VD( brush motor and brushless motor ) with up to 200A working current.  
All the drivers are CE and ROHS compliant and various of communication buses are available.
  - 1.3. 2-Phase / 3-Phase stepper system has standard and intelligent models for customer' choice. MOTEC steppers products have been widely used in many industries including military applications.
  - 1.4. MOTEC coreless servo system provide wide range motors for customer's choice from 4w to 250w (brush motor and brushless motor). With its 80Khz chopping frequency, MOTEC coreless servo driver can achieve excellent performances working with Maxon or Faulhaber coreless motors. MOTEC intelligent coreless servo driver is available with integrated motion controller and communication bus features.
  - 1.5. MOTEC can design and manufacture customized servo&stepper system for customers from various industrial where general servo and stepper systems cannot meet customer's requirements, ie servo and stepper driver for laser cutting machine and engraving machine, customized designed stepper and servo system for medical and military industrial, which require high level protection features. MOTEC has achieved a IP portfolio of various of invention patents, utility models and software copyrights over the years.
  - 1.6. EM servo electric cylinder is MOTEC's patent products developed by its mechatronics R&D team and it has been widely used in aviation, military and civilian industries with its high reliability, high performances and value for money features. EM60, EM80, EM110 and EM150 are models designed for civilian applications.
2. MOTEC planetary gearbox has been servicing customer for nearly 10 years and tens of thousands of them have been used in different applications working with MOTEC stepper and servo products and proved its reliability and performances.
3. MOTEC multi-channel CNC and standalone motion controller/card, with its excellent high response feature, have been successfully applied in various of industries across China and the world.
4. MOTEC cartesian robot is another masterpiece product developed by MOTEC R&D team. Currently MOTEC cartesian robot products has a sale volume of approximately 100 per annum.

MOTEC is a high-tech company with professional staff working in its motion control, stepper and servo driver, mechanical R&D teams. MOTEC takes its customers and employees as its valuable treasure and MOTEC believes the real value of the company is to achieve customers satisfactory and its employee's satisfactory as well.

The final goal of MOTEC is to become a True Value Implementer in motion control industrial in China, and the world.

**MOTEC Group (China)**

# Intelligent DC Servo System

## MOTEC<sup>®</sup> Intelligent DC Servo System(Standard Version)

- ▶ Intelligent DC Servo System Introduction (1~6)
- ▶ Intelligent DC Servo System Specifications (7~8)
- ▶ Model Nomenclature (9~10)
- ▶ DC Servo Driver&Motor Matching Table (11~12)
- ▶ DC Servo Driver (13~28)

- Dragonfly
- Bee
- Hummingbird
- Swallow
- Eagle
- Bear
- Hippo
- Elephant

- ▶ DC Brushless Servo Motors (29~39)
- ▶ DC Servo System Cables (40~43)
- ▶ DC Servo System Customization (44)
- ▶ MOTEC<sup>®</sup> Product Family Members (45~46)



BEAR



SWLOW

## ▶ MOTEC<sup>®</sup> Intelligent DC Servo System Intelligent DC Servo System Introduction

MOTEC intelligent DC servo system(standard version) is a series of DC servo system indepently delveoped by MOTEC R&D team featuring integrated servo driver, motion controller and optional PLC function. It can be easily controlled by PC, Touch Panel, PLC or third party controllers via various communication bus. MOTEC intelligent DC servo system is a value for money products with high power density and abundant features and functions.

- Integrated DC servo driver, motion controller and PLC
- Supply ladder diagram programing
- Support MOTECIAN, MODBUS, CANOPEN
- Support RS232,RS485,CAN BUS and USB communication <sup>①</sup>
- Support varioud of encoders
- Open instruction set and programing library are available
- Network control mode, pulse control mode, analog mode, PLC mode, PWM mode.
- Special version for harsh environment available
- Customization available

<sup>①</sup> USB communication only available for limited products. Please contact MOTEC sales team to confirm.

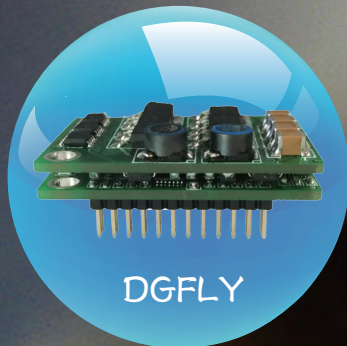

# Intelligent DC Servo System Introduction

MOTEC Intelligent DC Servo System has standard version and high performance version for customer's choice, Standard version is designed for domestic and industrial applications. High performance version is designed for special applications require special specifications ie extremely low working temperature etc. MOTEC DC servo driver(standard version) is suitable for MOTEC series DC motor as well as most brush/brushless motors on the market. It provides 3~50 amps continuing current and various of feedbacks options.



## Control Functions

- Benefit from its integrated features, MOTEC DC intelligent servos system allow users to manage servo driver, motion controller and PLC (utilizing ladder programming) within one product to achieve simple, reliable and powerful motion control.
  - Support USB, RS232, RS485 and CAN Bus. Support MOTECIAN, MODBUS and CANOPEN protocols.
  - S-curve velocity and T-curve velocity generation. Continuing multi-phase motion control under T-curve function.
  - Support multiple control mode including Network Mode, Pulse&Direction Mode, PLC Mode( optional). Support multiple operational mode including Position Mode, Speed Mode, Analog Mode and Current (Torque) Mode. Support real-time switching between modes(static status).
  - Support real-time switching between multiple gain control settings and multiple speed monitoring settings, resulting high system response while no influence to the stability performance.
  - MotionLib and Instruction Set allow users to program a control station software quickly
- Integrated temperature protection, overcurrent protection, overvoltage protection, undervoltage protection, out of tolerance position protection, out of tolerance speed protection, I<sup>2</sup>T current protection, etc.

## Communications

Four communication interfaces (mode) are available for MOTEC DC Servo System. Except USB mode, users can select any one of the rest three modes to build their multi-points motion control application. RS232 was designed for point to point communication but MOTEC has renovated it to suite multi-point control.

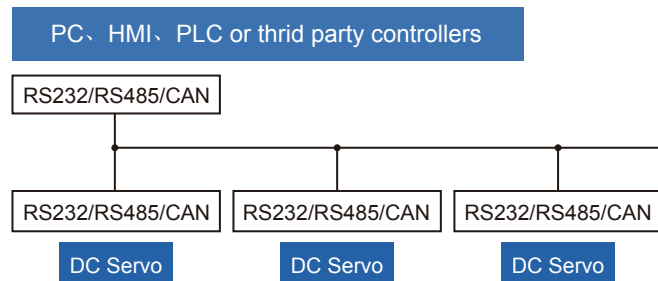

### MOTECIAN

MOTECIAN is a protocol developed by MOTEC and it can run through USB, RS232, RS485 and CAN Bus interfaces. We recommend MOTECIAN if users intend to develop their own host control applications.

### MODBUS

MODBUS protocol can be used to link MOTEC DC Servo system with HMI, PC or other Host Controller supporting Modbus through RS232 or RS485 interfaces.

### CANOPEN

CANOPEN protocol can be used on CAN BUS, CiA DS-301 and CiA DS-402 protocols are supported. Users can establish communication with MOTEC DC servo system under PDO or SDO mode. MOTEC dedicated channel is also available for customer's conveniences.

### Velocity Generation

S-curve and T-curve velocity generation are standard function module in MOTEC DC servo system. Users can select one from the two modes based on the actual needs in their application, ie for position control purpose or speed control purpose. The two modes are both available for position control purpose but only T mode is available when MOTEC DC servo system is used to do speed control. Both of the two modes can be used to do point to point motion control and position set value can be adjusted reguarly or irregularly during the motion process. Under T-curve mode, motors' maximum speed and acceleration speed (positive or negative) can be adjusted and applied immediately.

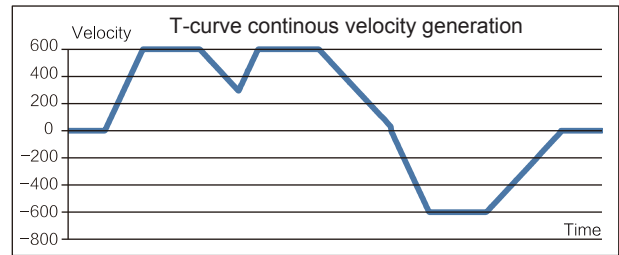
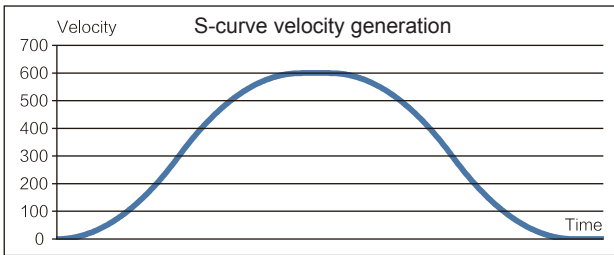

### Configuration Software

MotionStudio is a PC based configuration software which can do real time servo motor control, servo parameter setting and debugging via USB/RS232/485 interface. Users can easily get their parameter setting and debugging jobs done benefit from MotionStudio's graphic user interface and its powerful oscilloscope function.

#### Main Functions

- Monitor servo driver status
- Servo driver parameters setting
- Monitor through oscilloscope. Curve data savable.
- Motion control parameters setting
- I/O ports setting and monitoring
- Position, Speed, Current mode setting

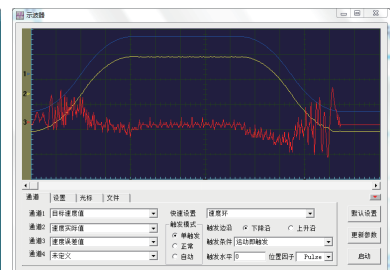

### Library

MotionLib provides affluent library functions to MOTEC intelligent DC servo system users for their host control programming purposes. Users can easily develop their own PC based application controlling multiple MOTEC intelligent DC Servo units via RS485 network without worrying about lower level serial ports operations.

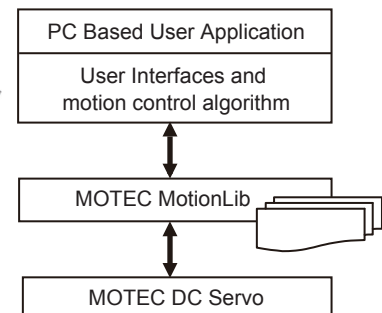

# Intelligent DC Servo System Introduction

## Integrated PLC

MOTEC intelligent DC Servo System integrated PLC functions internally. Users can program their PLC application using MotionPainter, which is a ladder diagram programming software developed by MOTEC. There are abundant RELAY and REGISTER resources enable users to build up motion control applications flexibly without external motion controllers. The benefit from this innovation is not only the saved hardware costs but also the improved system reliability and maintainability.

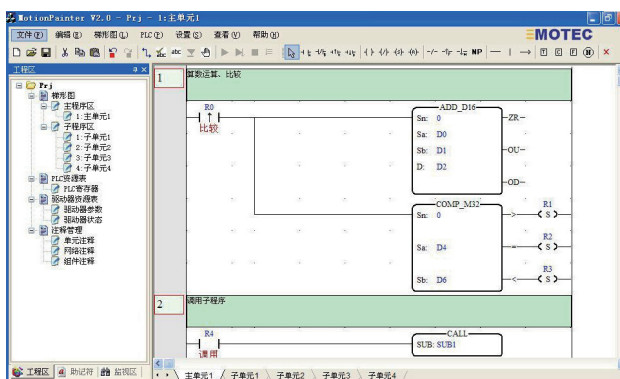

PLC寄存器表

显示选择:  自定义显示  范围显示 D显示范围: 0 ~ 0 重置 刷新

编号	类型	数值 (H)	数值 (D)	注释	说明
D0	0	0	0	直接模式速度	
D2	0	0	0	直接模式距离	
D10	0	0	0	间接模式速度	
D12	0	0	0	间接模式距离	
D20	0	0	0	暂停转速缓存	
D30	0	0	0	往复运动开始延时长度	
D40	0	0	0	往复运动容许转速	
D42	0	0	0	往复运动向右时距离	
D50	0	0	0	往复模式向左定时器	
D60	0	0	0	向左速度	
D62	0	0	0	向右速度	
D70	0	0	0	垂直向上时间	
D200	0	0	0	暂停转速缓存	
D202	0	0	0	正向制动距离	
D204	0	0	0	负向制动距离	
D210	0	0	0	正向转速	
D400	0	0	0	暂停结束后需要运行的距离	
D408	0	0	0	暂停前目标位置	
D508	0	0	0	暂停时已运行距离	

16位二进制  16位无符号  16位有符号  32位二进制  32位无符号  32位有符号  32位浮点数

寄存器: D0 0 修改 添加 删除 寄存器查找 查找

## Real-time Gain Control Switching

- Switching between three set of gain control settings.
- Three gain control switch modes for customer's choice.
- Switching can be done in any circumstances without causing motor vibration.
- The speed of switch process can be controlled by gain control switch filter settings.

## PWM Mode

- PWM mode supports position control, speed control and current control.
- The duty ratio of PWM signal sent from motion controller is used as the signal controlling the motion of the motors.
- Acceleration/deceleration value can be set. Smooth transition can be achieved even with acceleration/deceleration jump.
- Servo driver working status monitoring from host station is available under PWM mode.

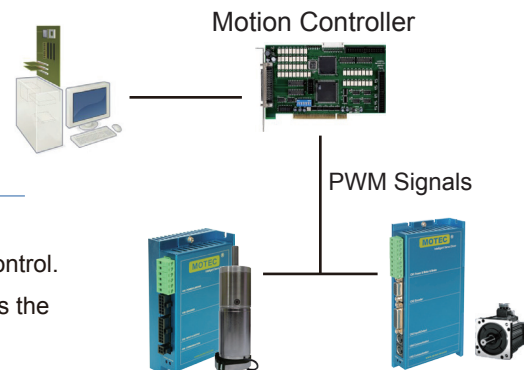

Intelligent DC Servo

### PWM Chopping Frequency

- MOTEC DC intelligent servo drivers are based on 32bits DSP and cutting edge control algorithm with 80kHz chopping frequency, which is capable of dealing with various of DC servo motors including corless motor, which features extremely low inductance.
- The PWM chopping frequency of MOTEC DC intelligent servo drivers are adjustable (16kHz、32kHz、48kHz、64kHz、80kHz) and have been successfully driving many kinds of DC servo motors (brush and brushless) from manufacturers across the world.

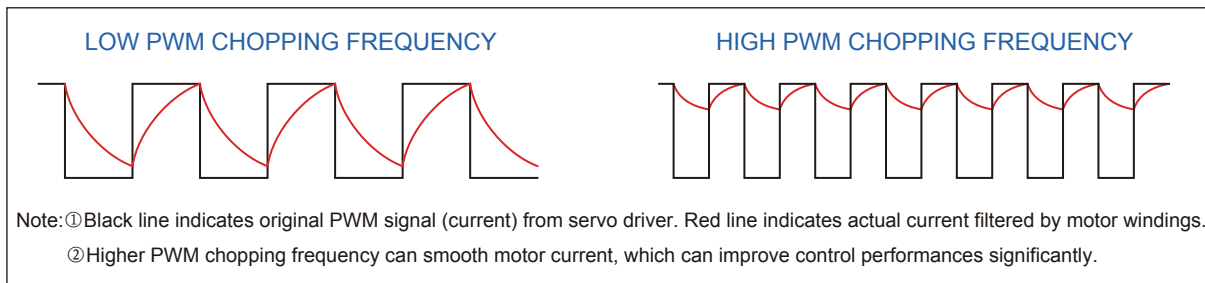

In a PWM circuit of a motor driver, the actual motor driving output is consecutive pulse signals with variable pulse width. Because of the inductance feature of stator windings (higher frequencies can pass through easier than lower frequencies), stator windings play as a better filter on high frequency input signals in comparing to low frequency signals. And the higher the inductance, the better the filter effect. Coreless motor is a motor without iron core to achieve high response speed and high effectiveness. The inductance of its motor windings is extremely low comparing to those motors with iron cores. A typical inductance of a coreless motor is only 1/5~1/10 of inductance of a normal motor. As a result a normal DC servo motor driver ( typical PWM frequency at 10-20kHz ) cannot be used to drive a coreless motor with satisfactory control performance. The solution is to increase the PWM frequency of the driver and it has been proved as a successful solution.

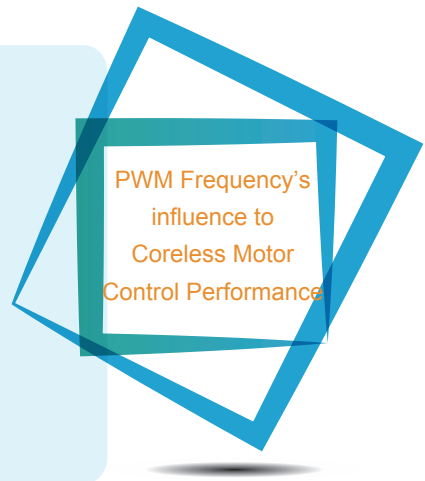

### PVT Mode(Optional)

PVT (Position, Velocity, Time) is a control mode allowing users to establish a complicated motion control process by setting up a series of position and speed points with a fixed time interval. PVT mode enable users to build up sophisticated applications need multi axis interpolation and collaboration without consuming a lot of communication resources using MOTEC intelligent servo systems.

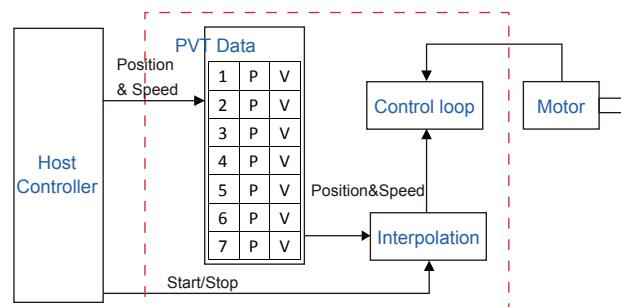

# Intelligent DC Servo System Introduction

Position and speed data can be sent to internal PVT queue via communication instructions for PVT operation. Position and speed data can also be stored in internal flash memory of MOTEC DC intelligent servo driver for single or multiple loading&running.

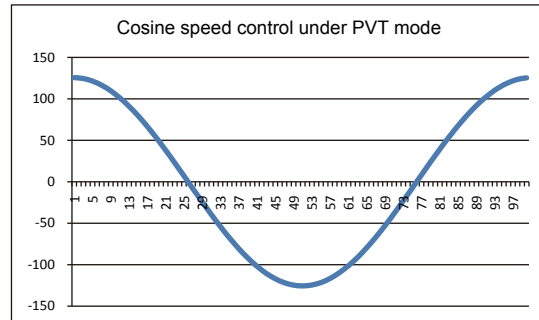
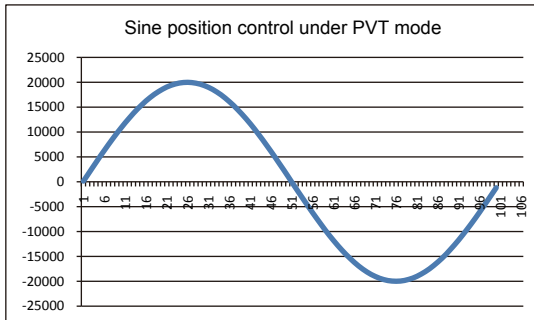

## Speed Coefficient

MOTEC intelligent DC Servo has three internal speed coefficients Pr.62、 Pr.63、 Pr.64, which applied to motor acceleration&deceleration, uniform motion and static status, to achieve best motor control performances. Please refer to MOTEC DC Servo System Users Manual for details about speed coefficients setting.

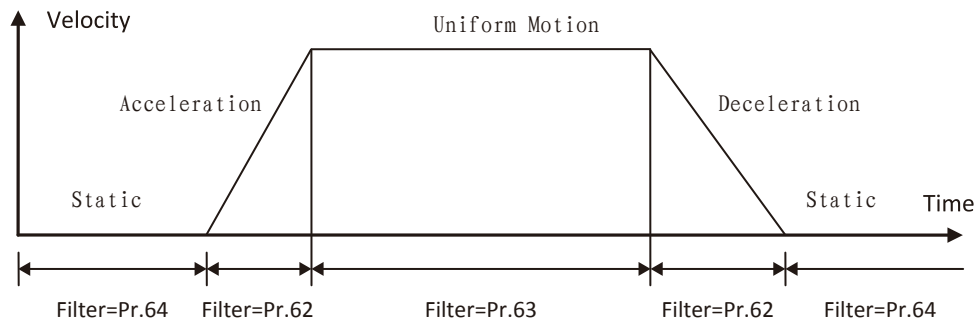

Different Speed Coefficients under different motion status

## Customization

Customized DC servo driver and/or motor can be ordered from MOTEC with special specifications and performances including DC servo system with high reliability or special control functions. Please contact MOTEC sales team or your local MOTEC distributor when our standard products cannot meet your requirements.

### MOTEC<sup>®</sup> Intelligent DC Servo System Specifications

Specs	Power Supply		12.5VDC~180VDC	
	Max continue current		3A~50A	
	Enviroment <sup>※1</sup>	Temperature	Working Temperature :0℃~50℃ ; Storage Temperature:-20℃ ~ 60℃	
		Humidity	Below 5G; 10HZ~60HZ	
		Vibration	PWM Chopper Control	
	Method of Control		PWM Chopper Control. PWM Frequency 16KHz ~ 80KHz	
	Encoder Supported		Serial magnetic encoder, Incremental encoder, Resolver,Hall sensor	
	Communication <sup>※2</sup>	USB	1:1 communication, support MOTECIAN	
		RS232	1:8 communication, support MOTECIAN、Modbus	
		RS485	1:31 communication, support MOTECIAN、Modbus	
		CAN	1:110 communication, support MOTECIAN、CANOPEN	
	Position Loop Frequency		4KHZ	
	Speed Loop Frequency		4KHZ	
	Current Loop Frequency		16KHZ	
	Input / Output		Please refer to model specifications	
Pulse Signal		Pulse/Direction and CW/CCW		
Analog Signal		One ±10V Analog Input ( please refer to model specifications)		
PWM Signal		One PWM Input . Input frequency100HZ~100KHZ(please refer to model specifications)		
Func tions	Network Mode	Position Control	S-curve, acceleration, jerk, max acceleration controllabl. T-curve acceleration, jerk, max jerk controllable. Position and T-curve setting can be adjusted during motion	
		Speed Control	T-curve acceleration controllable. Speed and acceleration setting can be adjusted during motion	
		Current Control	Max Speed Limit setting available. Current smooth filter available.	
	Analog Mode	Position Control	T-curve max speed, acceleration, jerk controllable. Poistion setting refreshing frequency is 1KHz. Analog input filter available.	
		Speed Control	T-curve acceleration controllable. Poistion setting refreshing frequency is 1KHz. Analog input filter available.	
		Current Control	Max Speed Limit setting available. Current smooth filter available.	
	PWM Mode	Position Control	T-curve max speed, acceleration controllable. Poistion setting refreshing frequency is 1KHz. PWM input filter available.	
		Speed Control	T-curve acceleration controllable. Poistion setting refreshing frequency is 1KHz. PWM input filter available.	
		Current Control	Max Speed Limit setting available. PWM smooth filter available.	

# Intelligent DC Servo Driver Specifications

## MOTEC® Intelligent DC Servo System Functions

Functions	PWM Mode	Note	Under PWM Mode, users need to set up PWM input frequency to increase the PWM Duty Ratio Recognition Accuracy to achieve better performance and system stability.
	Pulse/Direction Mode	Input	Support Pulse/Direction signal and CW/CCW signal
		Voltage	+5V/+24VDC (*Under 24VDC onditions, a series resisitor is necessary for opto-isolated pulse/direction inputs but not necessary for non opto-isolated inputs)
		Frequency	500KHZ
		Electronic Gear	Frequency of instruction pulse × $\frac{\text{Fractions of Electronic Gear}(1\sim 65535)}{\text{Numerator of Electronic Gear}(1\sim 65535)}$ *Limit from 1/1000 to1000
		Filter	First order smooth filter available
PLC Mode		PLC ladder diagram programming Switch between position control, speed control and current control when static Applications can be triggered by I/O or instructions via communication network	
Others	Mode Switch	Switch between different control modes and operational modes without limit ( static )	
	Limits	Soft limits and hardware limits available	
	Alarm	Overvoltage, undervoltage, temperature, I <sup>2</sup> T, position & speed out of tolerance, peak current	
	Alarm History	8 alarm history available including current alarm	
	Gain Control	Real-time switch between different gain control settings	
	Speed Monitor	Multiple speed monitor parameters real-time switch	
	Library	Enable users to create PC based application software easily	
I/O Functions	Functions Available for Input Ports	1. Motor Enable/Release      2. Clear Alarm 3. Positive Limit                4. Negative Limit 5. Positive Jog                  6. Negative Jog 7. Find home                    8. Homing Switch 9. Stop Motion                 10. Urgent Stop 11. Pulse Stop                  12. Zero Speed Brake	
	Function available for Output Ports	1. Servo Ready                  2. Alarm Output 3. Position Reached            4. Speed Reached 5. Current Reached              6. Brake Output 7. Zero Speed Output	

※1 Please refer to MOTEC Military Class DC/AC Servo products catalogue if working in extremely harsh environments.

※2 Number of units in one communication network subjects to onsite environment, band rate and cable length etc.

### MOTEC<sup>®</sup> DC Servo Driver Model Nomenclature

#### Standard Version

**HIPPO – 80 – 20 – E – S – AC – P – CXX**

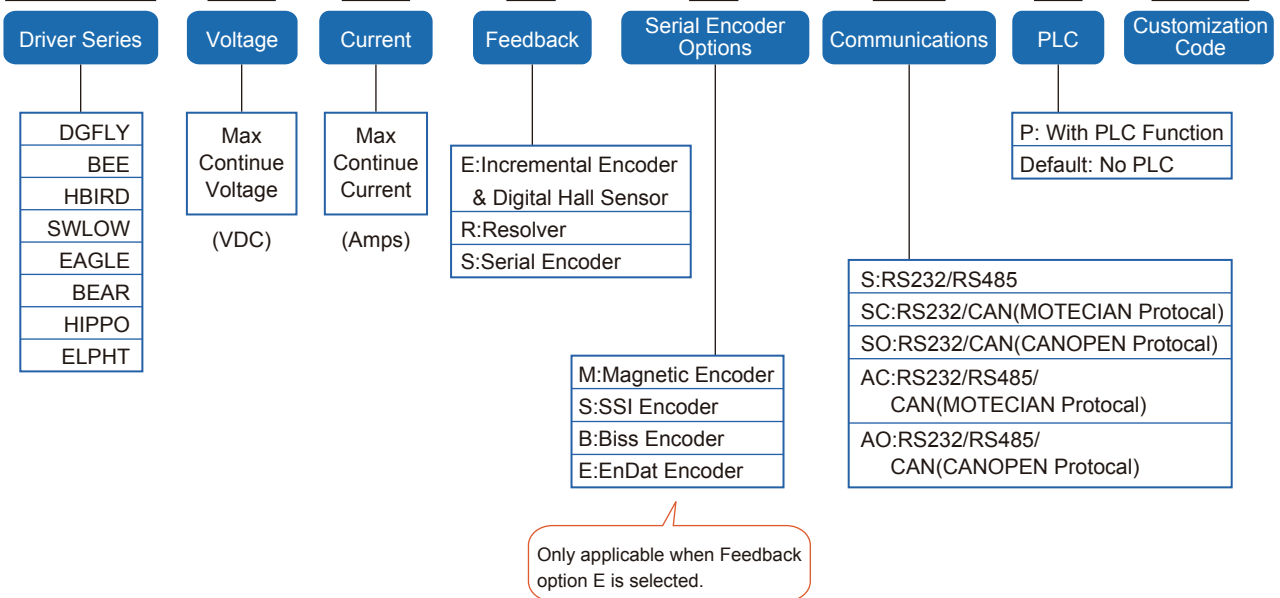

Note: Not all the combinations are available.  
 Serial encoder is only available for BEAR80-15 Series.  
 Resolver is only available for ELPHT80-30 Series.

# DC Servo System Model Nomenclature

## MOTEC® DC Servo Motor Model Nomenclature

### Low Voltage DC Servo Motor

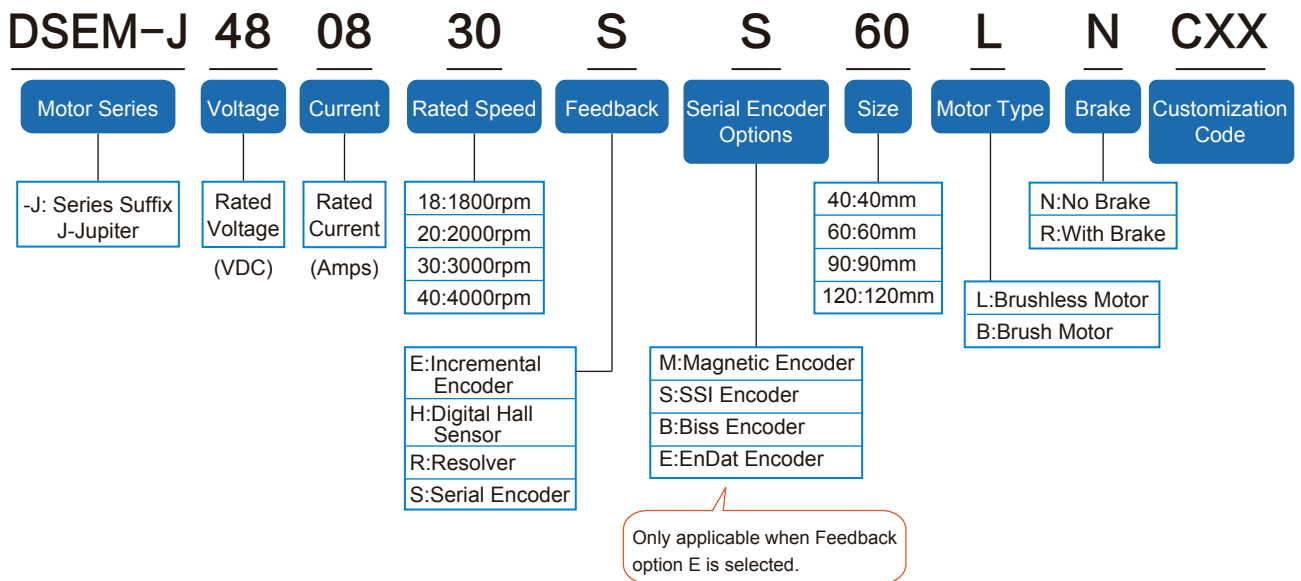

### DC Coreless Motor

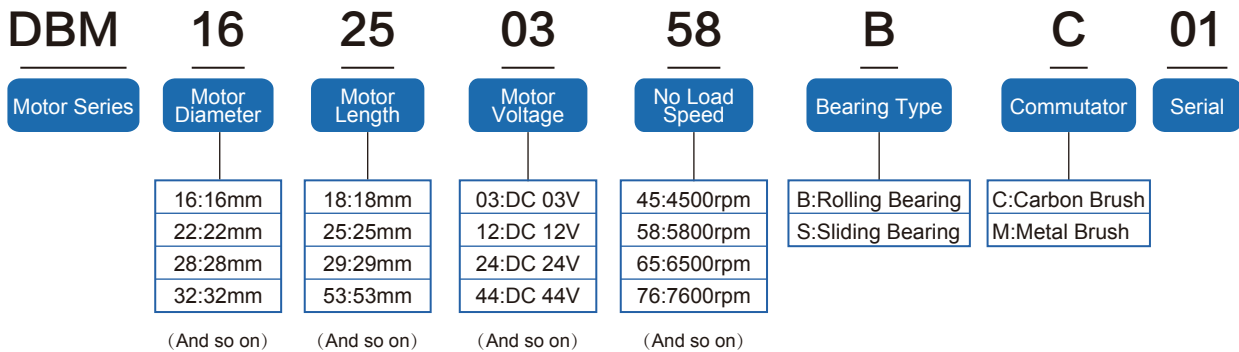

Note:

Please refer to P29~P39 of this catalogue for more details of MOTEC low voltage DC motors.

Please refer to MOTEC DC coreless motor catalogue for more details of DBM coreless motors.

### MOTEC<sup>®</sup> Intelligent DC Servo Driver&Motor Matching Table

#### Standard Version

Driver Model	Max Continue Voltage(V)	Max Continue Current(A)	Driver Dimensions (mm)	Driver Mass (Kg)	Communications	Suitable Motors
DGFLY-36-03-E-SC	36	03	45×30×20	0.03	RS232和CAN(MOTECIAN Protocal)	Brush/Brushless, DC Coreless Motor
DGFLY-36-03-E-SO	36	03	45×30×20	0.03	RS232和CAN(CANOPEN Protocal)	
BEE-36-06-E-SC	36	06	78×47×16	0.05	RS232和CAN(MOTECIAN Protocal)	Brush and DC Coreless Motor
BEE-36-06-E-SO	36	06	78×47×16	0.05	RS232和CAN(CANOPEN Protocal)	
HBIRD-36-06-E-AC	36	06	75×50×20.6	0.05	RS232、RS485和CAN(MOTECIAN Protocal)	Brush/Brushless, DC Coreless Motor
HBIRD-36-06-E-AO	36	06	75×50×20.6	0.05	RS232、RS485和CAN(CANOPEN Protocal)	
SWLOW-36-08-E-AC	36	08	65×18×105	0.11	RS232、RS485和CAN(MOTECIAN Protocal)	
SWLOW-36-08-E-AO	36	08	65×18×105	0.11	RS232、RS485和CAN(CANOPEN Protocal)	
EAGLE-48-12-E-AC	48	12	78×41×132	0.38	RS232、RS485和CAN(MOTECIAN Protocal)	Brush/Brushless
EAGLE-48-12-E-AO	48	12	78×41×132	0.38	RS232、RS485和CAN(CANOPEN Protocal)	
BEAR-80-15-E-AC	80	15	93×30×181	0.45	RS232、RS485和CAN(MOTECIAN Protocal)	Brush/Brushless
BEAR-80-15-E-AO	80	15	93×30×181	0.45	RS232、RS485和CAN(CANOPEN Protocal)	
HIPPO-80-20-E-AC	80	20	93×44×181	0.89	RS232、RS485和CAN(MOTECIAN Protocal)	Brush/Brushless
HIPPO-80-20-E-AO	80	20	93×44×181	0.89	RS232、RS485和CAN(CANOPEN Protocal)	
HIPPO-160-12-E-AC	160	12	93×44×181	0.89	RS232、RS485和CAN(MOTECIAN Protocal)	
HIPPO-160-12-E-AO	160	12	93×44×181	0.89	RS232、RS485和CAN(CANOPEN Protocal)	
ELPHT-80-30-E-AC	80	30	100×85×141	1.03	RS232、RS485和CAN(MOTECIAN Protocal)	Brush/Brushless
ELPHT-80-30-E-AO	80	30	100×85×141	1.03	RS232、RS485和CAN(CANOPEN Protocal)	
ELPHT-80-30-R-AC	80	30	100×85×141	1.03	RS232、RS485和CAN(MOTECIAN Protocal)	
ELPHT-80-30-R-AO	80	30	100×85×141	1.03	RS232、RS485和CAN(CANOPEN Protocal)	
ELPHT-80-50-E-AC	80	50	100×85×141	1.03	RS232、RS485和CAN(MOTECIAN Protocal)	Brush/Brushless
ELPHT-80-50-E-AO	80	50	100×85×141	1.03	RS232、RS485和CAN(CANOPEN Protocal)	
ELPHT-80-50-R-AC	80	50	100×85×141	1.03	RS232、RS485和CAN(MOTECIAN Protocal)	
ELPHT-80-50-R-AO	80	50	100×85×141	1.03	RS232、RS485和CAN(CANOPEN Protocal)	

## DC Servo Driver&Motor Matching Table

Driver Model	Max Continue voltage(V)	Max Continue Current(A)	Driver Dimensions (mm)	Driver Mass (Kg)	Communications	Suitable Motors
ELPHT-160-30-E-AC	160	30	100×85×141	1.03	RS232、RS485和CAN(MOTECIAN Protocol)	Brush/ Brushless
ELPHT-160-30-E-AO	160	30	100×85×141	1.03	RS232、RS485和CAN(CANOPEX Protocol)	
ELPHT-160-30-R-AC	160	30	100×85×141	1.03	RS232、RS485和CAN(MOTECIAN Protocol)	
ELPHT-160-30-R-AO	160	30	100×85×141	1.03	RS232、RS485和CAN(CANOPEX Protocol)	

## MOTEC<sup>®</sup> DC Servo Motors

MOTEC low voltage DC servo motors are made with powerful magnetic materials and features low noise , low heat production, low vibration, long working hours etc. It has been widely used in many industries working with kinds of position sensors.

No.	Motor Type	Motor Model	Rated Voltage (VDC)	Rate Current (Amps)	Rated Speed (RPM)	Rated Torque (Nm)
1	Brushless	DSEM-J240440E40L*	24	3.28	4000	0.144
2	Brushless	DSEM-J240540E40L*	24	4.92	4000	0.215
3	Brushless	DSEM-J240730E60L*	24	7	3000	0.32
4	Brushless	DSEM-J241218E60L*	24	12.1	1800	1.06
5	Brushless	DSEM-J242530E90L*	24	26.64	3000	1.3
6	Brushless	DSEM-J480240E40L*	48	1.63	4000	0.144
7	Brushless	DSEM-J480340E40L*	48	2.40	4000	0.215
8	Brushless	DSEM-J480830E60L*	48	8.4	3000	0.91
9	Brushless	DSEM-J481230E60L*	48	12	3000	1.3
10	Brushless	DSEM-J482030E90L*	48	20	3000	2.4
11	Brushless	DSEM-J483020E120L*	48	31.26	2000	5.25

\* Indicates options. R indicates motor with brake. N indicates motor without brake.

\* Above is a limited list of typical DC motors MOTEC can supply and more motor models are available for customer's choice.

Please contact MOTEC sales team if above specifications could not meet your requirements



### MOTEC<sup>®</sup> DGFLY DC Servo Driver Models

Series	Voltage(V)	Current(A)	Feedback	Communication	PLC Options	Note
DGFLY	36	03	E	SC	PLC	Peak Current 9A
	36	03	E	SO	No PLC	Peak Current 9A

Note: E indicates incremental encoder and digital Hall sensor feedback.

SC indicates RS232 and CAN (MOTECIAN Protocol) communication. SO Indicates RS232 and CAN(CANOPEN Protocol) communication.

### MOTEC<sup>®</sup> DGFLY DC Servo Driver Features

- Working voltage 12.5VDC~36VDC
- Max continue working current 3A
- Working temperature: 0°C~50°C
- 4 digital input, 2 digital output, 1 ±10VDC Analog input
- Position control mode, speed control mode and current control mode
- 4kHz control frequency for position&speed control and 16kHz for current control
- Support S-curve and T-curve velocity generation
- PWM chopping frequency 16k~80kHz adjustable(Multiplied value of 16k)
- Network mode, pulse/direction mode, analog mode, PWM mode and optional PLC mode
- RS232 and CAN Bus communications. 8 units network for RS232 and 110 units network for CAN Bus
- Initial baudrate 115200bps for RS232 and 1Mbps for CAN Bus
- Support MOTECIAN、MODBUS、CANOPEN protocols. Instructions set and libraries available
- Incremental encoder and Hall sensor feedback
- Alarm and protection for overvoltage,undervoltage, temperature,I<sup>2</sup>T,position&speed out of tolerance, peak current
- Suitable for brush&brushless motor and coreless DC motor
- Very low mass at 0.03kg
- Very small size at 45mm(L)×30mm(W)×20mm(H)

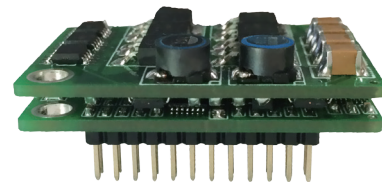

### MOTEC<sup>®</sup> DGFLY DC Servo Driver Dimensions

Unit: mm

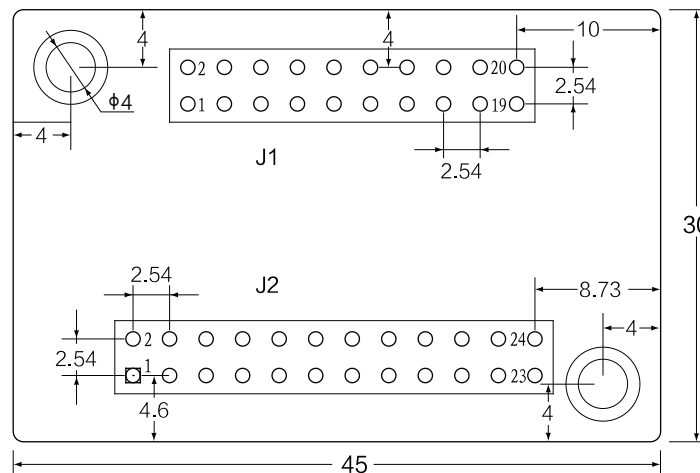

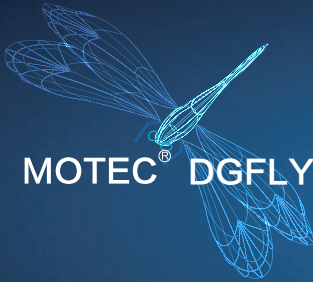

# MOTEC<sup>®</sup> DGFLY DC Servo Driver

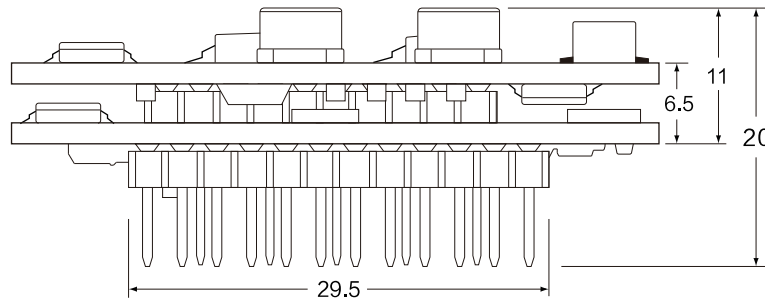
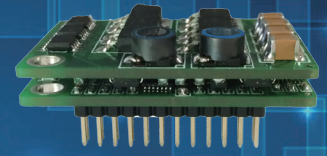

## MOTEC<sup>®</sup> DGFLY DC Servo Driver Wiring Diagram (With brushless Motor)

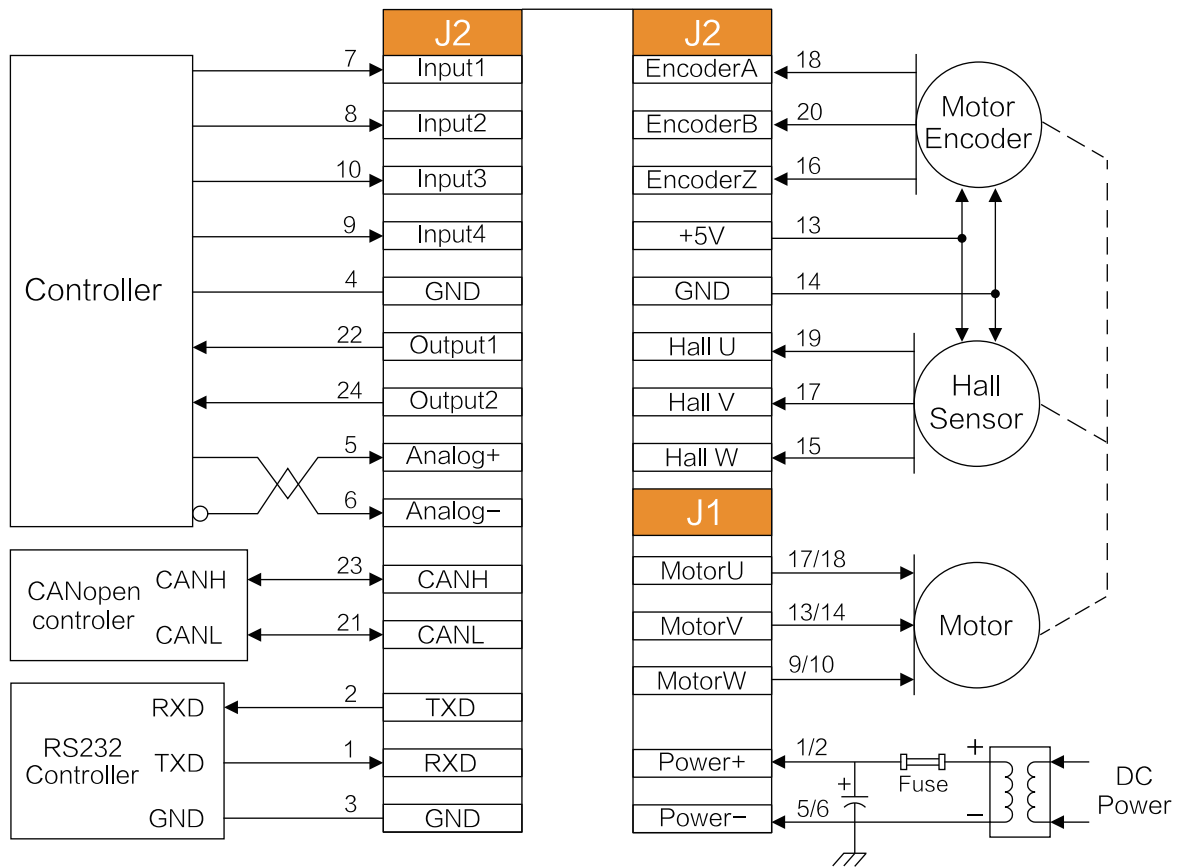

Default	Multiplexed
Input1	PULSE/PWM
Input2	DIR

Note: 1、 Input voltage range +5VDC~+24VDC

2、 Output voltage range 0~+5VDC

3、 For brush motor MOTOR + connected to Motor V and MOTOR - connected to Motor W



### MOTEC<sup>®</sup> BEE Series DC Servo Driver Models

Series	Voltage(V)	Current(A)	Feedback	Communication	PLC Options	Note
BEE	36	06	E	SC	PLC	Peak Current 18A
	36	06	E	SO	No PLC	Peak Current 18A

Note: E indicates incremental encoder and digital Hall sensor feedback.

SC indicates RS232 and CAN (MOTECIAN Protocol) communication. SO Indicates RS232 and CAN(CANOPEN Protocol) communication.

### MOTEC<sup>®</sup> BEE DC Servo Driver Features

- Working voltage 12.5VDC~36VDC
- Max continue working current 6A
- Working temperature: 0°C~50°C
- 3 digital input, 2 digital output, 1 ±10VDC Analog input
- Position control mode, speed control mode and current control mode
- 4kHz control frequency for position&speed control and 16kHz for current control
- Support S-curve and T- curve velocity generation
- PWM chopping frequency 16k~80kHz adjustable ( Multiplied value of 16k )
- Network mode, pulse/direction mode, analog mode, PWM mode and optional PLC mode
- RS232 and CAN Bus communications. 8 units network for RS232 and 110 units network for CAN Bus
- Initial baudrate 115200bps for RS232 and 1Mbps for CAN Bus
- Support MOTECIAN、MODBUS、CANOPEN protocols. Instructions set and libraries available
- Incremental encoder feedback
- Alarm and protection for overvoltage, undervoltage, temperature, I<sup>2</sup>T, position&speed out of tolerance, peak current
- Suitable for brush motor and coreless DC motor
- Very low mass at 0.05kg
- Very small size at 78mm(L)×47mm(W)×16mm(H)



### MOTEC<sup>®</sup> BEE DC Servo Driver Dimensions

Unit: mm

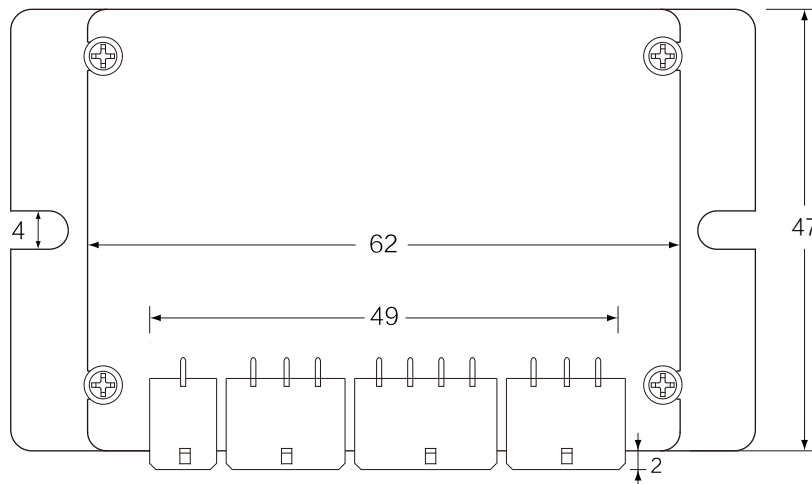



# MOTEC<sup>®</sup> BEE DC Servo Driver

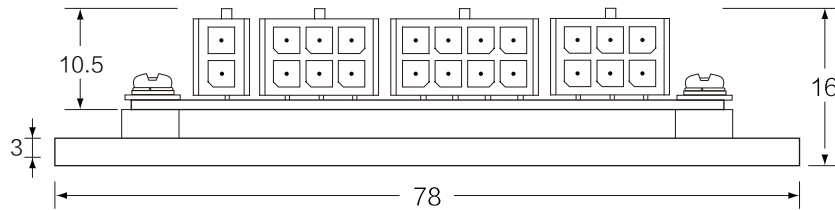
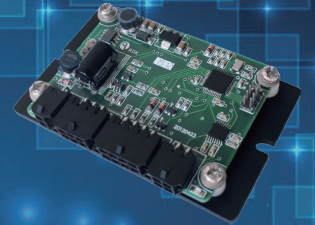

## MOTEC<sup>®</sup> BEE DC Servo Wiring Diagram

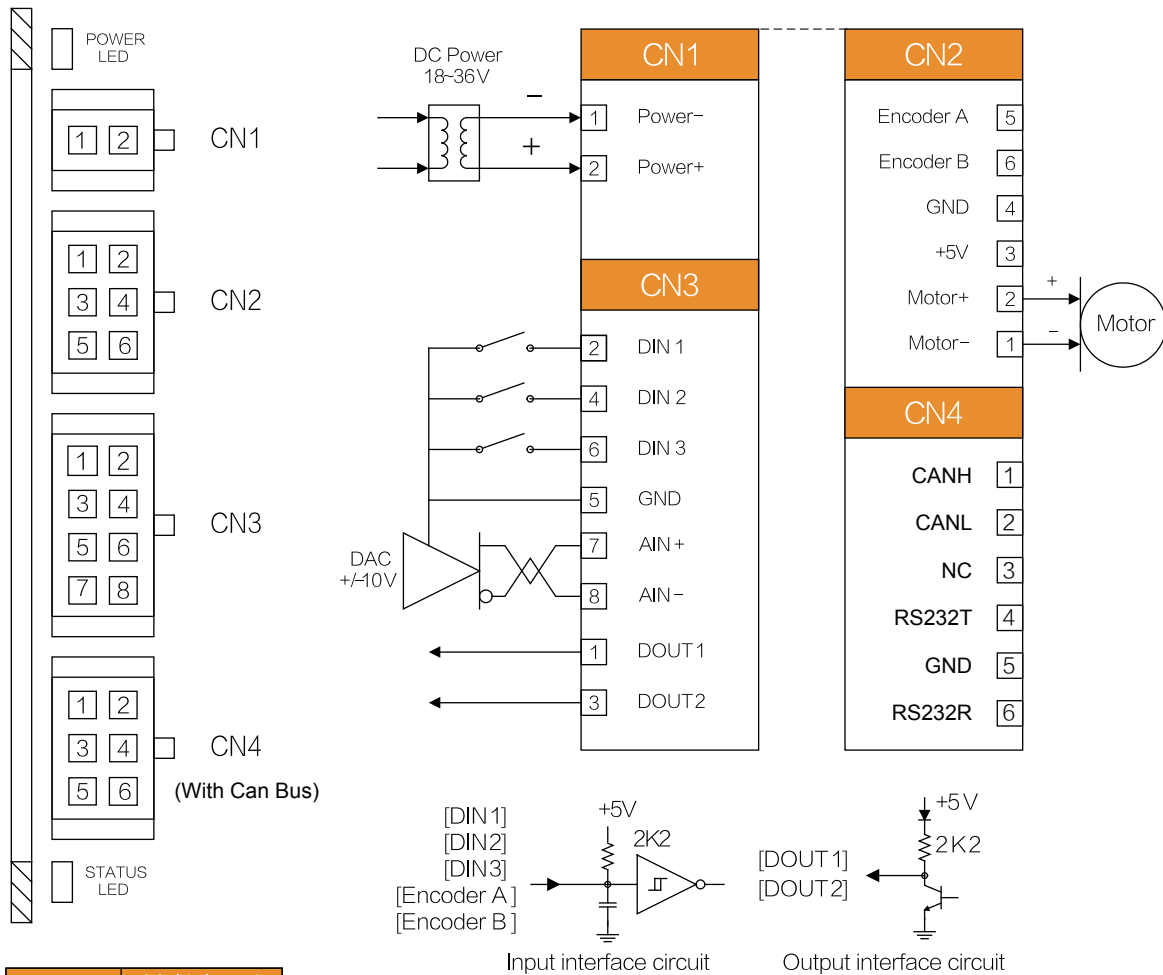

Default	Multiplexed
DIN1	DIR
DIN2	PULSE/PWM
DIN3	ENABLE

Note: 1、 Input voltage range +5VDC~+24VDC  
 2、 Output voltage range 0~+5VDC

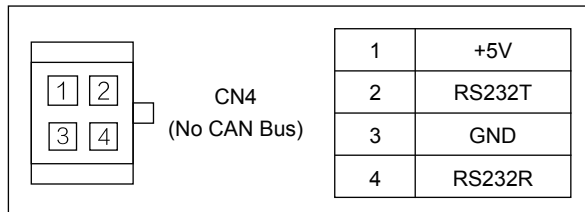

Intelligent DC Servo



### MOTEC<sup>®</sup> HBIRD DC Servo Driver Models

Series	Voltage(V)	Current(A)	Feedback	Communication	PLC Options	Note
HBIRD	36	06	E	AC	PLC	Support USB,Peak Current12A
	36	06	E	AO	No PLC	Support USB,Peak Current12A

Note: E indicates incremental encoder and digital Hall sensor feedback.

AC indicates RS232,RS485 and CAN (MOTECIAN Protocol) communication. AO Indicates RS232, RS485 and CAN(CANOPEN Protocol) communication.

### MOTEC<sup>®</sup> HBIRD DC Servo Driver Features

- Working voltage 12.5VDC~36VDC
- Max continue working current 6A
- Working temperature: 0°C~50°C
- 3 digital input, 2 digital output, 1 ±10VDC Analog input
- Position control mode, speed control mode and current control mode
- 4kHz control frequency for poistion&speed control and 16kHz for current control
- Support S-curve and T- cureve velocity generation
- PWM chopping frequency 16k~80kHz adjustable ( Multiplied value of 16k )
- Network mode, pulse/direction mode, analog mode, PWM mode and optional PLC mode
- RS232/485 and CAN Bus communications. 8 units network for RS232, 31 units network for RS 485 and 110 units network for CAN Bus
- Initial baudrate 115200bps for RS232/485 and 1Mbps for CAN Bus
- Support MOTECIAN、MODBUS、CANOPEN protocols. Instructions set and libraries available
- Incremental encoder and digital Hall sensor feedback
- Alarm and protection for overvoltage,undervoltage, temperature,I<sup>2</sup>T,position&speed out of tolerance, peak current
- Suitable for brush/brushless motor and coreless DC motor
- Very low mass at 0.05kg
- Very small size at 75mm(L)×50mm(W)×20.6mm(H)

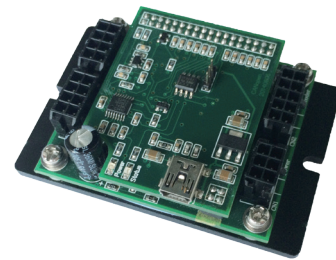

### MOTEC<sup>®</sup> HBIRD DC Servo Driver Dimensions

Unit: mm

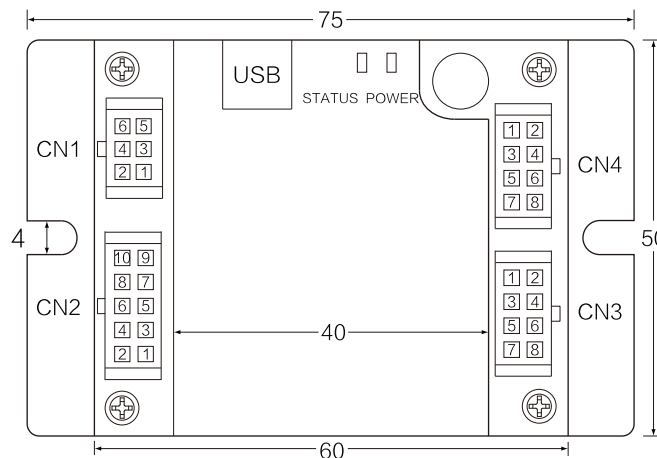



# MOTEC<sup>®</sup> HBIRD DC Servo Driver

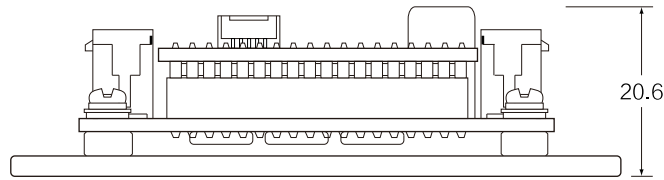
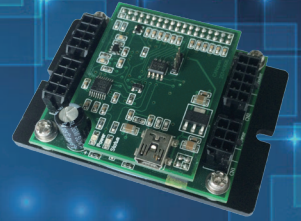

## MOTEC<sup>®</sup> HBIRD DC Servo Driver Wiring Diagram (with brushless motor)

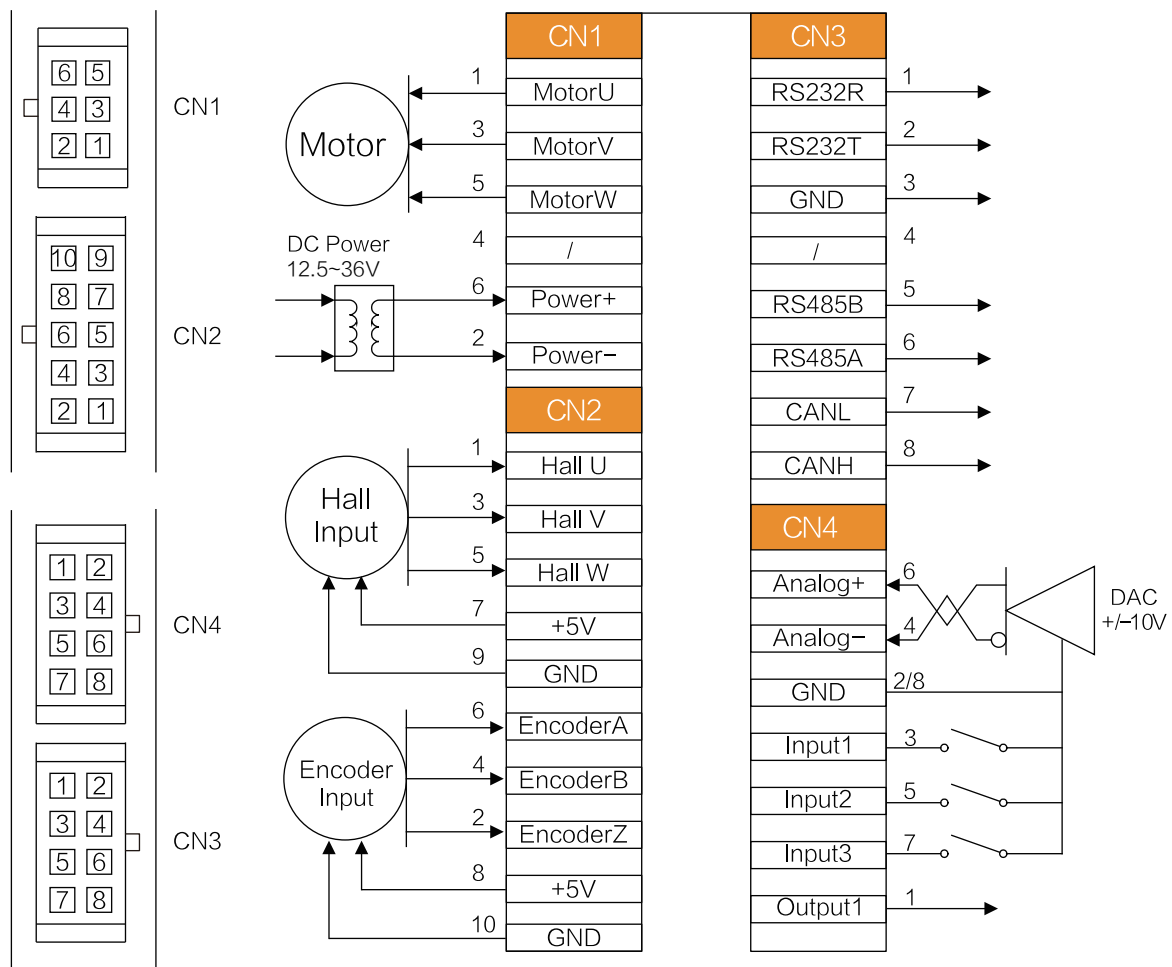

Default	Multiplexed
Input1	PULSE/PWM
Input2	DIR
Input3	ENABLE

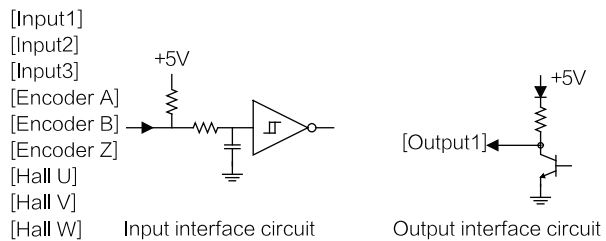

Note: 1、 Input voltage range +5VDC~+24VDC

2、 Output voltage range 0~+5VDC

3、 For brush motor MOTOR + connected to Motor V and MOTOR - connected to Motor W

Intelligent DC Servo



### MOTEC<sup>®</sup> SWLOW DC Servo Driver Models

Series	Voltage(V)	Current(A)	Feedback	Communication	PLC Options	Note
SWLOW	36	08	E	AC	PLC	Peak Current 16A
	36	08	E	AO	No PLC	Peak Current 16A

Note: E indicates incremental encoder and digital Hall sensor feedback.

AC indicates RS232,RS485 and CAN (MOTECIAN Protocol) communication. AO Indicates RS232, RS485 and CAN(CANOPEN Protocol) communication.

### MOTEC<sup>®</sup> SWLOW DC Servo Driver Features

- Working voltage 18VDC~36VDC. Max continue working current 8A
- Working temperature: 0°C~50°C
- 6 digital input, 2 digital output, 1 ±10VDC Analog input
- Position control mode, speed control mode and current control mode
- 4kHz control frequency for poistion&speed control and 16kHz for current control
- Support S-curve and T- cureve velocity generation
- PWM chopping frequency 16k~80kHz adjustable ( Multiplied value of 16k )
- Network mode, pulse/direction mode, analog mode, PWM mode and optional PLC mode
- RS232/485 and CAN Bus communications. 8 units network for RS232, 31 units network for RS 485 and 110 units network for CAN Bus
- Initial baudrate 115200bps for RS232/485 and 1Mbps for CAN Bus
- Support MOTECIAN、MODBUS、CANOPEN protocols. Instructions set and libraries available
- Incremental encoder and digital Hall sensor feedback
- Alarm and protection for overvoltage,undervoltage, temperature,I<sup>2</sup>T,position&speed out of tolerance, peak current
- Suitable for brush/brushless motor and coreless DC motor
- Very low mass at 0.11kg and small size at 65mm(L)×18mm(W)×105mm(H)



### MOTEC<sup>®</sup> SWLOW DC Servo Driver Dimensions

Unit: mm

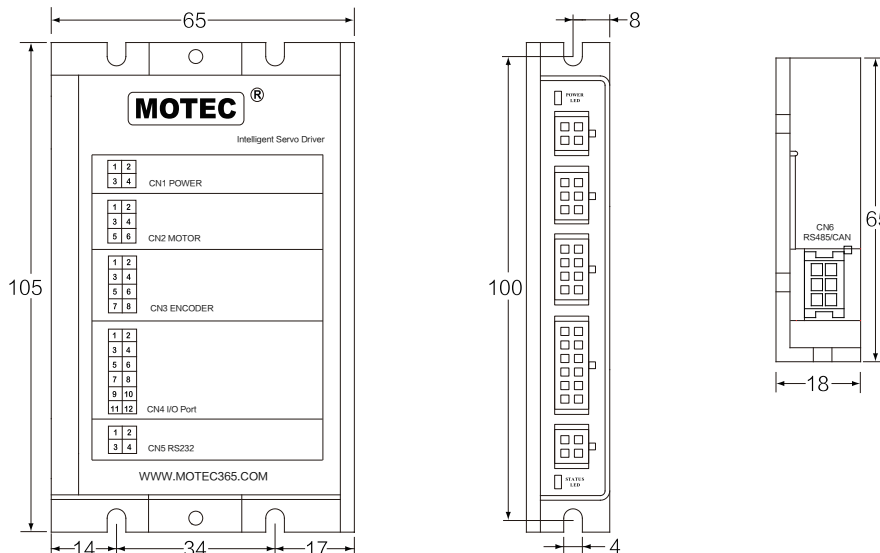



# MOTEC® SWLOW DC Servo Driver



## MOTEC® SWLOW DC Servo Driver Wiring Diagram (with brushless motor)

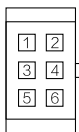
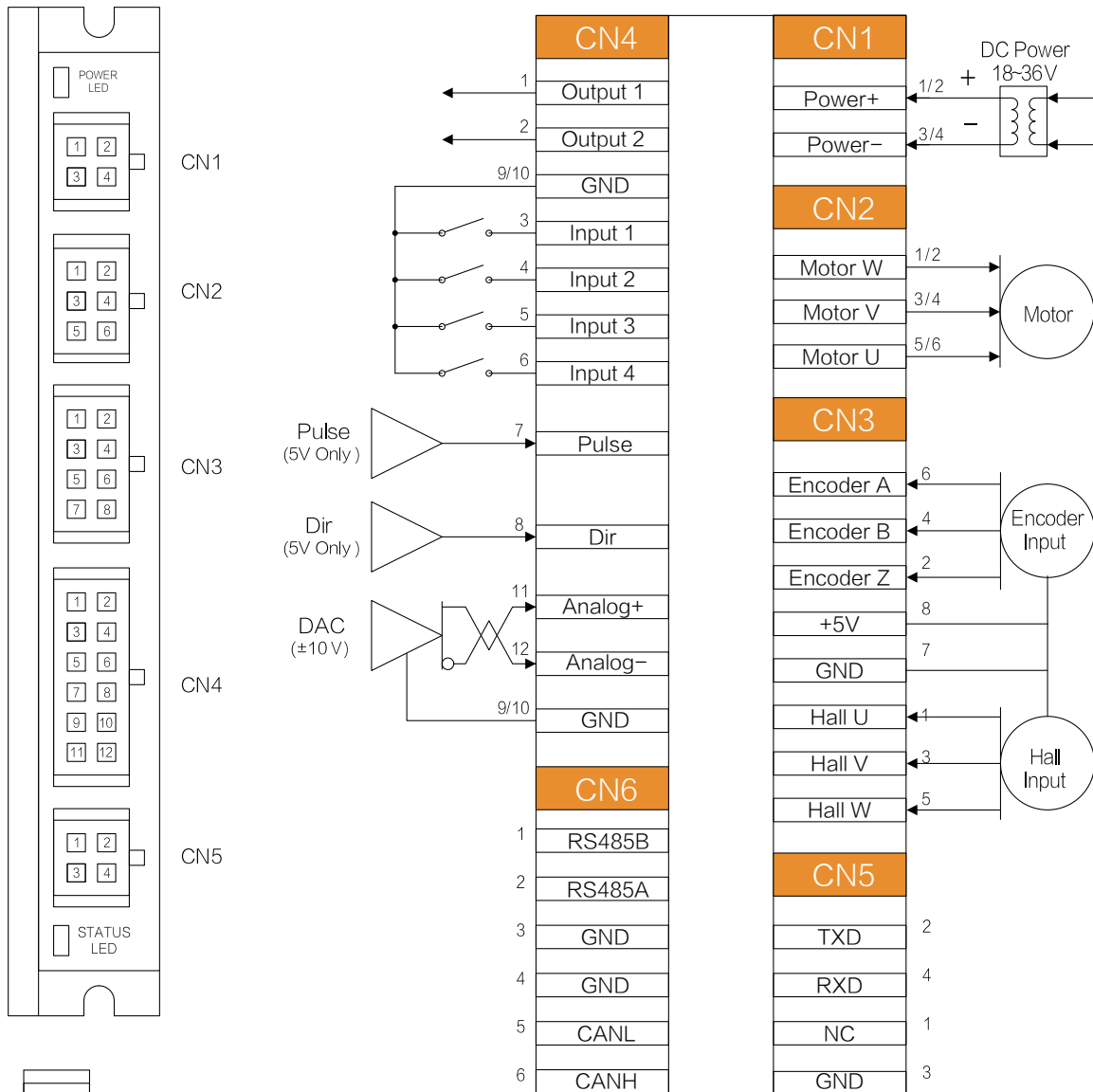

**CN6**  
RS485/CAN Communication connector  
located on the side of the driver

- Note:**
1. Input voltage range +5VDC~+24VDC
  2. Output voltage range 0~+5VDC
  3. For brush motor MOTOR + connected to Motor V and MOTOR - connected to Motor W

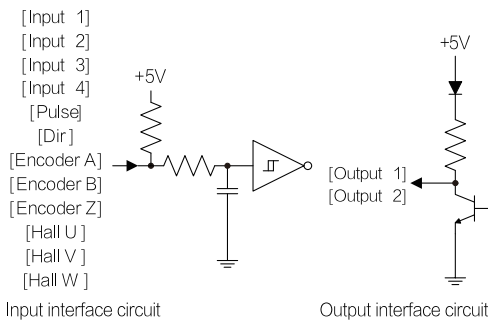

Intelligent DC Servo



### MOTEC<sup>®</sup> EAGLE DC Servo Driver Models

Series	Voltage(V)	Current(A)	Feedback	Communication	PLC Options	Note
EAGLE	48	12	E	AC	PLC	Peak Current 24A
	48	12	E	AO	No PLC	Peak Current 24A

Note: E indicates incremental encoder and digital Hall sensor feedback.

AC indicates RS232,RS485 and CAN (MOTECIAN Protocol) communication. AO Indicates RS232, RS485 and CAN(CANOPEN Protocol) communication.

### MOTEC<sup>®</sup> EAGLE DC Servo Driver Features

- Working voltage 18VDC~48VDC. Max continue working current 12A
- Working temperature: 0°C~50°C
- 6 digital input, 2 digital output, 1 ±10VDC Analog input
- Position control mode, speed control mode and current control mode
- 4kHz control frequency for position&speed control and 16kHz for current control
- Support S-curve and T- curve velocity generation
- PWM chopping frequency 16k~80kHz adjustable ( Multiplied value of 16k )
- Network mode, pulse/direction mode, analog mode, PWM mode and optional PLC mode
- RS232/485 and CAN Bus communications. 8 units network for RS232, 31 units network for RS 485 and 110 units network for CAN Bus
- Initial baudrate 115200bps for RS232/485 and 1Mbps for CAN Bus
- Support MOTECIAN、MODBUS、CANOPEN protocols. Instructions set and libraries available
- Incremental encoder and digital Hall sensor feedback
- Alarm and protection for overvoltage,undervoltage, temperature,I<sup>2</sup>T,position&speed out of tolerance, peak current
- Suitable for brush/brushless motor
- Low mass at 0.38kg and small size at 78mm(L)×41mm(W)×132mm(H)



### MOTEC<sup>®</sup> EAGLE DC Servo Driver Dimensions

Unit: mm

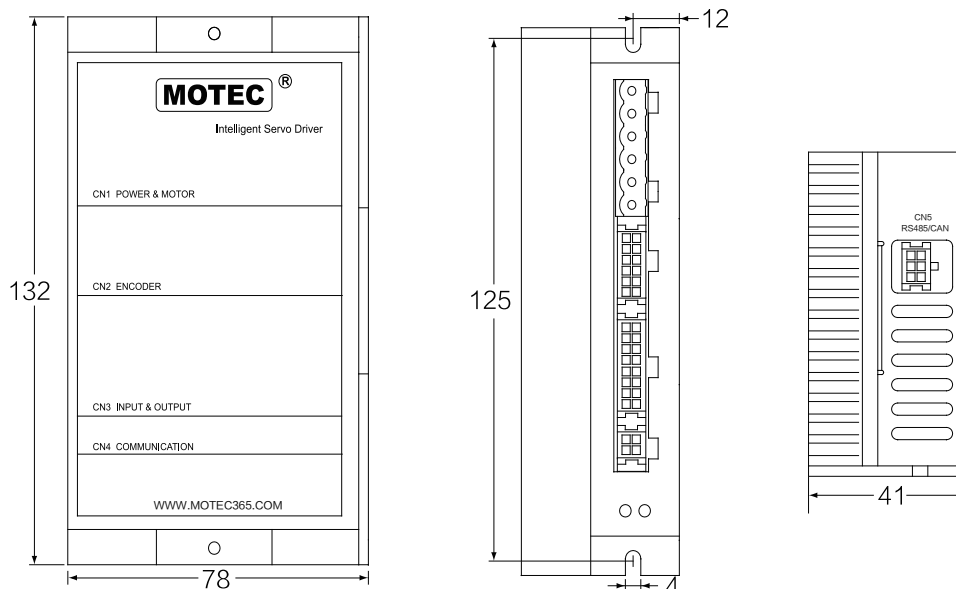



## MOTEC® EAGLE DC Servo Driver Wiring Diagram( with brush motor)

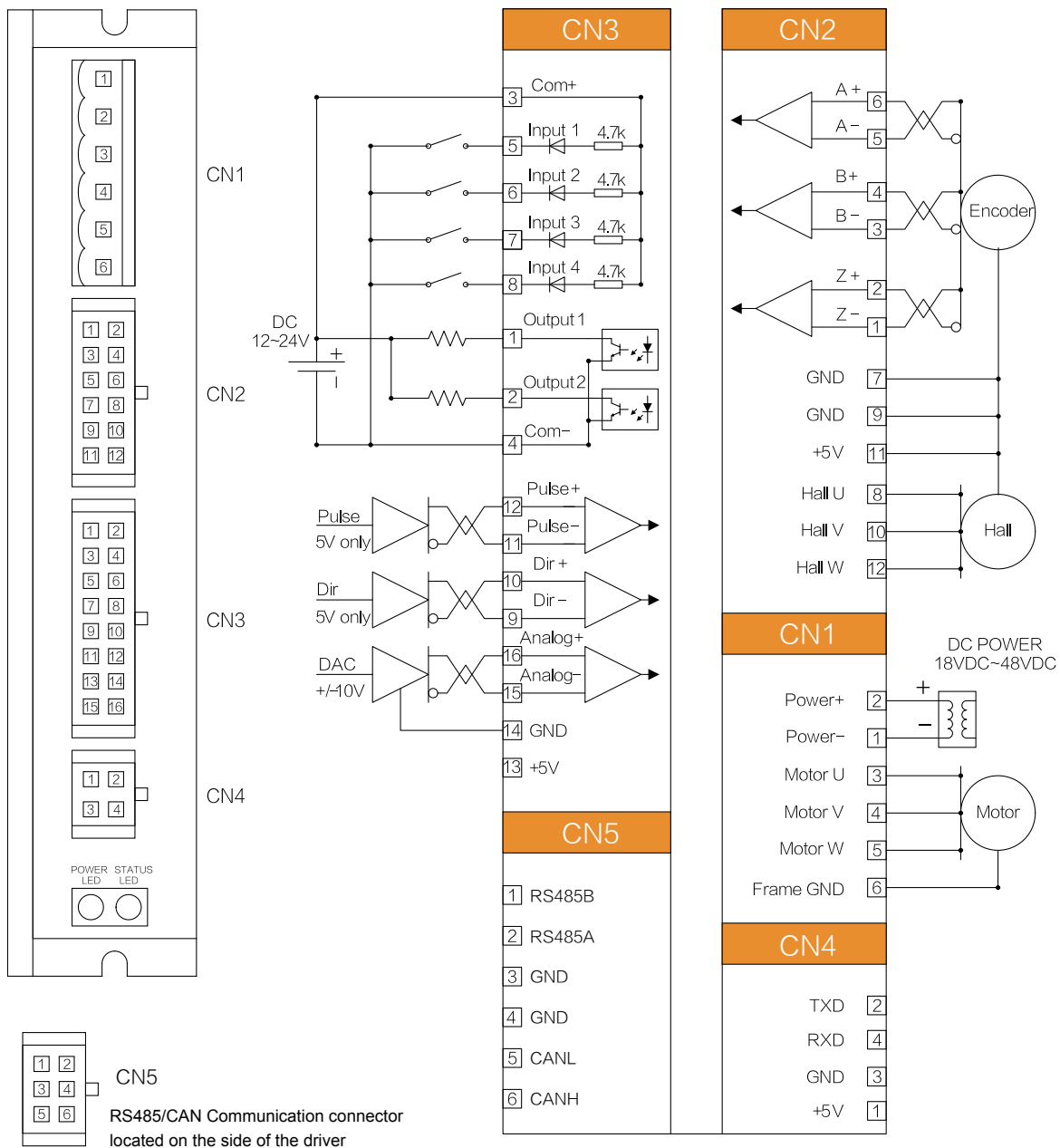

- Note: 1、 Pulse/Direction input voltage range +5VDC~+24VDC. 1K/0.25W resistor is needed when input is +12V signal  
2K/0.25W resistor is needed when input is +24VDC signal
- 2、 Other input voltage range +12VDC~+24VDC
- 3、 For brush motor MOTOR + connected to Motor V and MOTOR - connected to Motor W



### MOTEC® BEAR DC Servo Driver Models

Series	Voltage(V)	Current(A)	Feedback	Communication	PLC Options	Note
BEAR	80	15	E	AC	PLC	Peak Current 30A
	80	15	E	AO	No PLC	Peak Current 30A

Note: E indicates incremental encoder and digital Hall sensor feedback.

AC indicates RS232,RS485 and CAN (MOTECIAN Protocol) communication. AO Indicates RS232, RS485 and CAN(CANOPEN Protocol) communication.

### MOTEC® BEAR DC Servo Driver Features

- Working voltage 18VDC~80VDC. Max continue working current 15A
- Working temperature: 0°C~50°C
- 8 digital input, 2 digital output, 1 ±10VDC Analog input
- Position control mode, speed control mode and current control mode
- 4kHz control frequency for position&speed control and 16kHz for current control
- Support S-curve and T-curve velocity generation
- PWM chopping frequency 16k~80kHz adjustable ( Multiplied value of 16k )
- Network mode, pulse/direction mode, analog mode, PWM mode and optional PLC mode
- RS232/485 and CAN Bus communications. 8 units network for RS232, 31 units network for RS 485 and 110 units network for CAN Bus
- Initial baudrate 115200bps for RS232/485 and 1Mbps for CAN Bus
- Support MOTECIAN、MODBUS、CANOPEN protocols. Instructions set and libraries available
- Incremental encoder and digital Hall sensor feedback
- Temperature monitoring of driving module. Dedicated brake input.
- Alarm and protection for overvoltage,undervoltage, temperature,I<sup>2</sup>T,position&speed out of tolerance, peak current
- Suitable for brush/brushless motor
- Low mass at 0.45kg and small size at 93mm(L)×30mm(W)×181mm(H)



### MOTEC® BEAR DC Servo Driver Dimensions

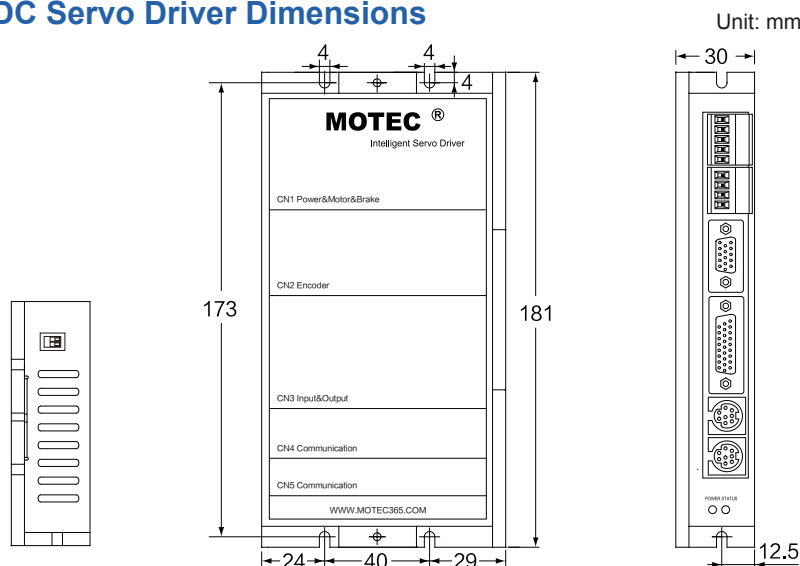

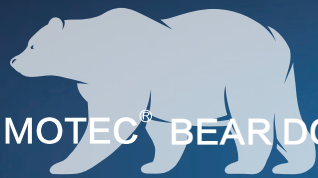

# MOTEC BEAR DC Servo Driver



## MOTEC BEAR DC Servo Driver Wiring Diagram ( with brushless motor )

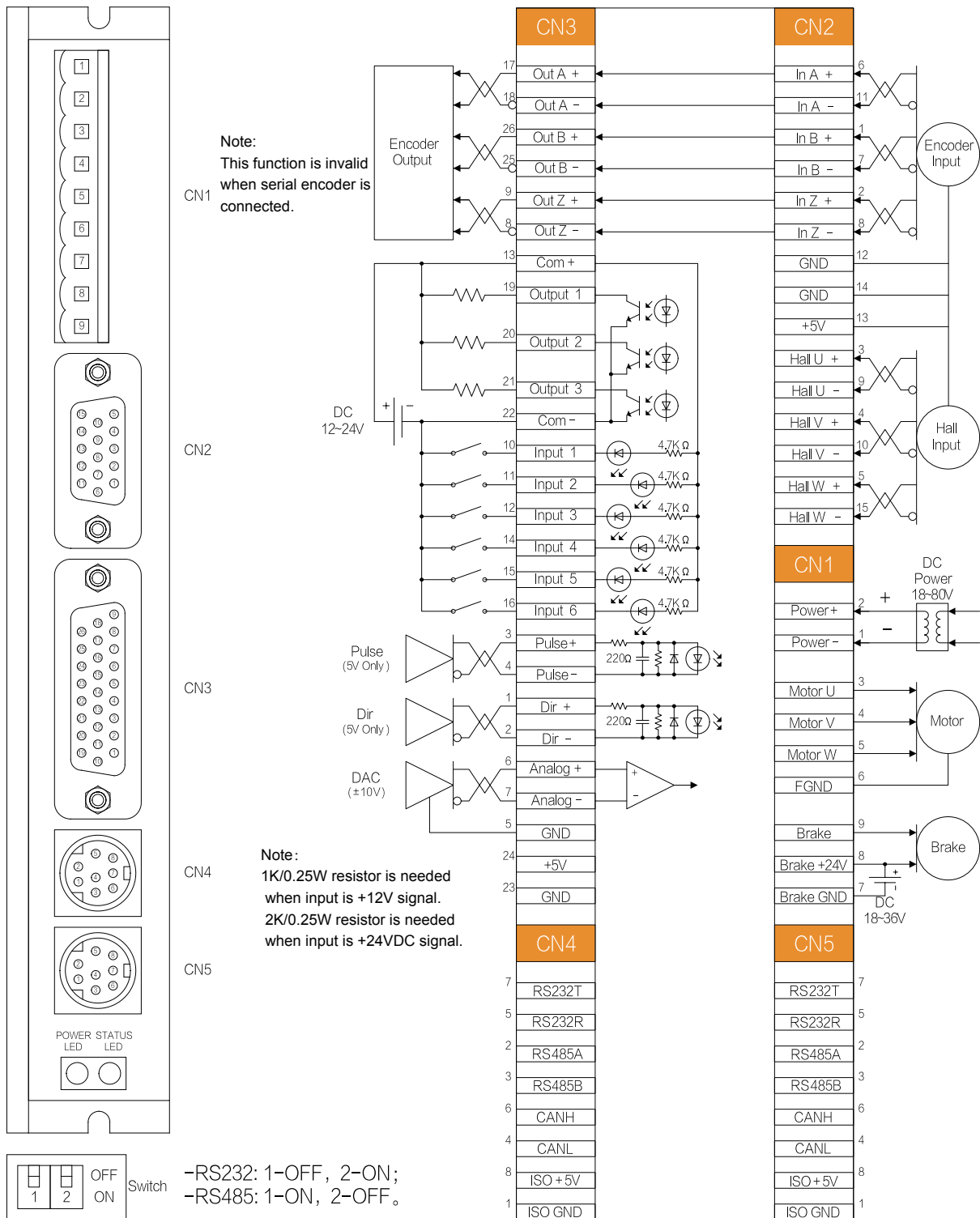



### MOTEC® HIPPO DC Servo Driver Models

Series	Voltage(V)	Current(A)	Feedback	Communication	PLC Options	Note
HIPPO	80	20	E	AC	PLC	Peak Current 40A
	80	20	E	AO	No PLC	Peak Current 40A
	160	12	E	AC	PLC	Peak Current 24A
	160	12	E	AO	No PLC	Peak Current 24A

Note: E indicates incremental encoder and digital Hall sensor feedback.

AC indicates RS232,RS485 and CAN (MOTECIAN Protocol) communication. AO Indicates RS232, RS485 and CAN(CANOPEN Protocol) communication.

### MOTEC® HIPPO DC Servo Driver Features

- Control power supply 18VDC~36VDC driving power supply 18VDC~160VDC.
- Max continuing working current 20A
- Working temperature: 0°C~50°C
- 8 digital input, 3 digital output, 1 ±10VDC Analog input
- Position control mode, speed control mode and current control mode
- 4kHz control frequency for position&speed control and 16kHz for current control
- Support S - curve and T - curve velocity generation
- PWM chopping frequency 16k~80kHz adjustable ( Multiplied value of 16k )
- Network mode, pulse/direction mode, analog mode, PWM mode and optional PLC mode
- RS232/485 and CAN Bus communications. 8 units network for RS232, 31 units network for RS 485 and 110 units network for CAN Bus
- Initial baudrate 115200bps for RS232/485 and 1Mbps for CAN Bus
- Support MOTECIAN、MODBUS、CANOPEN protocols. Instructions set and libraries available
- Incremental encoder and digital Hall sensor feedback
- Temperature monitoring of driving module.
- Alarm and protection for overvoltage,undervoltage, temperature,I<sup>2</sup>T,position&speed out of tolerance, peak current
- Suitable for brush/brushless motor
- Low mass at 0.89kg and small size at 93mm(L)×44mm(W)×181mm(H)



### MOTEC® HIPPO DC Servo Driver Dimensions

Unit: mm

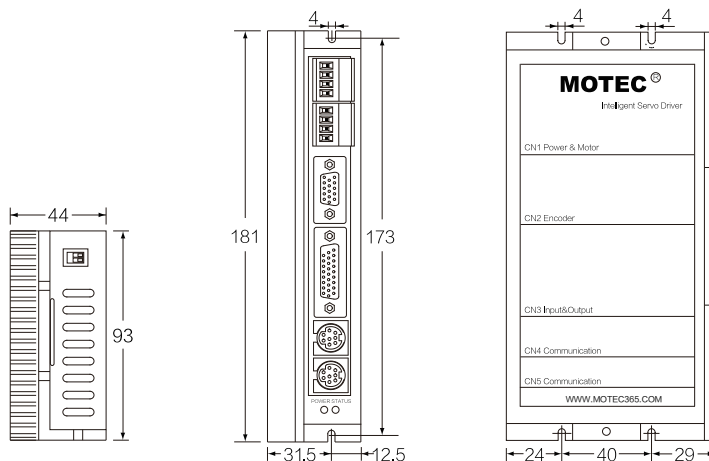



## MOTEC<sup>®</sup> HIPPO DC Servo Driver Wiring Diagram(with brushless motor)

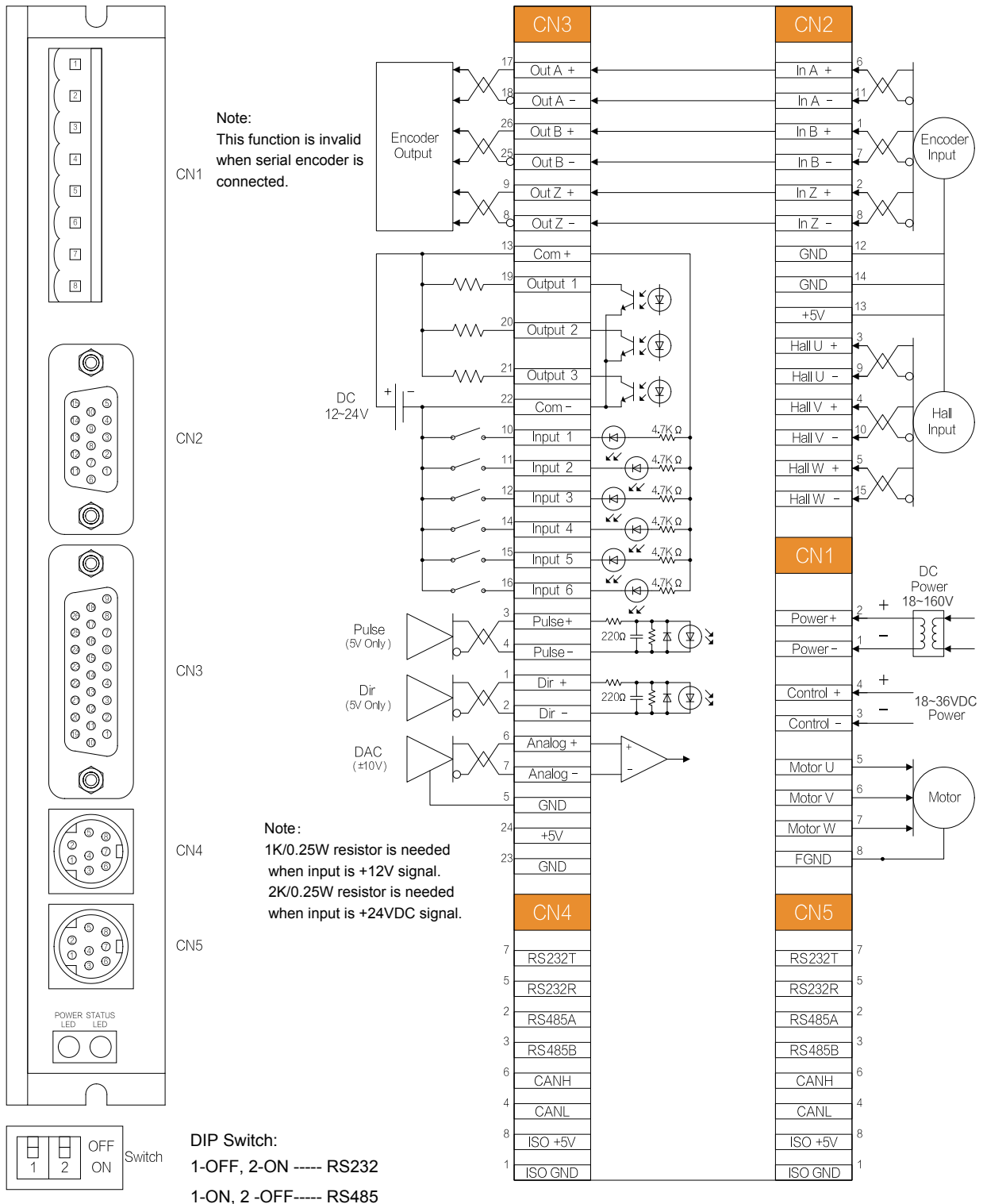

Note: For brush motor MOTOR + connected to Motor V and MOTOR - connected to Motor W



### MOTEC® ELPHT DC Servo Driver Models

Series	Voltage(V)	Current(A)	Feedback	Communication	PLC Options	Note
ELPHT	80	30	E/R	AC	PLC	Peak Current 60A
	80	30	E/R	AO	No PLC	Peak Current 60A
	80	50	E/R	AC	PLC	Peak Current 100A
	80	50	E/R	AO	No PLC	Peak Current 100A
	160	30	E/R	AC	PLC	Peak Current 60A
	160	30	E/R	AO	No PLC	Peak Current 60A

Note: E indicates incremental encoder and digital Hall sensor feedback.

AC indicates RS232,RS485 and CAN (MOTECIAN Protocol) communication. AO Indicates RS232, RS485 and CAN(CANOPEN Protocol) communication.

### MOTEC® ELPHT DC Servo Driver Features

- Control power supply 18VDC~36VDC driving power supply 18VDC~160VDC.
- Max continuing working current 50A
- Working temperature: 0°C~50°C
- 8 digital input, 3 digital output, 1 ±10VDC Analog input
- Position control mode, speed control mode and current control mode
- 4kHz control frequency for position&speed control and 16kHz for current control
- Support S - curve and T - curve velocity generation
- PWM chopping frequency 16k~80kHz adjustable ( Multiplied value of 16k )
- Network mode, pulse/direction mode, analog mode, PWM mode and optional PLC mode
- RS232/485 and CAN Bus communications. 8 units network for RS232, 31 units network for RS 485 and 110 units network for CAN Bus
- Initial baudrate 115200bps for RS232/485 and 1Mbps for CAN Bus
- Support MOTECIAN、MODBUS、CANOPEN protocols. Instructions set and libraries available
- Incremental encoder and digital Hall sensor feedback
- Temperature monitoring of driving module. Dedicated brake connector.
- Alarm and protection for overvoltage,undervoltage, temperature,I<sup>2</sup>T,position&speed out of tolerance, peak current
- Suitable for brush/brushless motor
- Low mass at 1.03kg and small size at 100mm(L)×85mm(W)×141mm(H)



### MOTEC® ELPHT DC Servo Driver Dimensions

Unit: mm

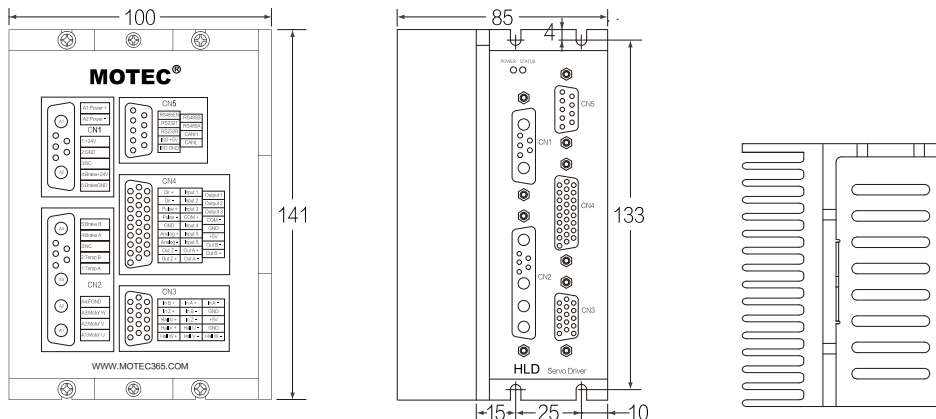



# MOTEC® ELPHT DC Servo Driver



## MOTEC® ELPHT DC Servo Driver Wiring Diagram (with brushless motor)

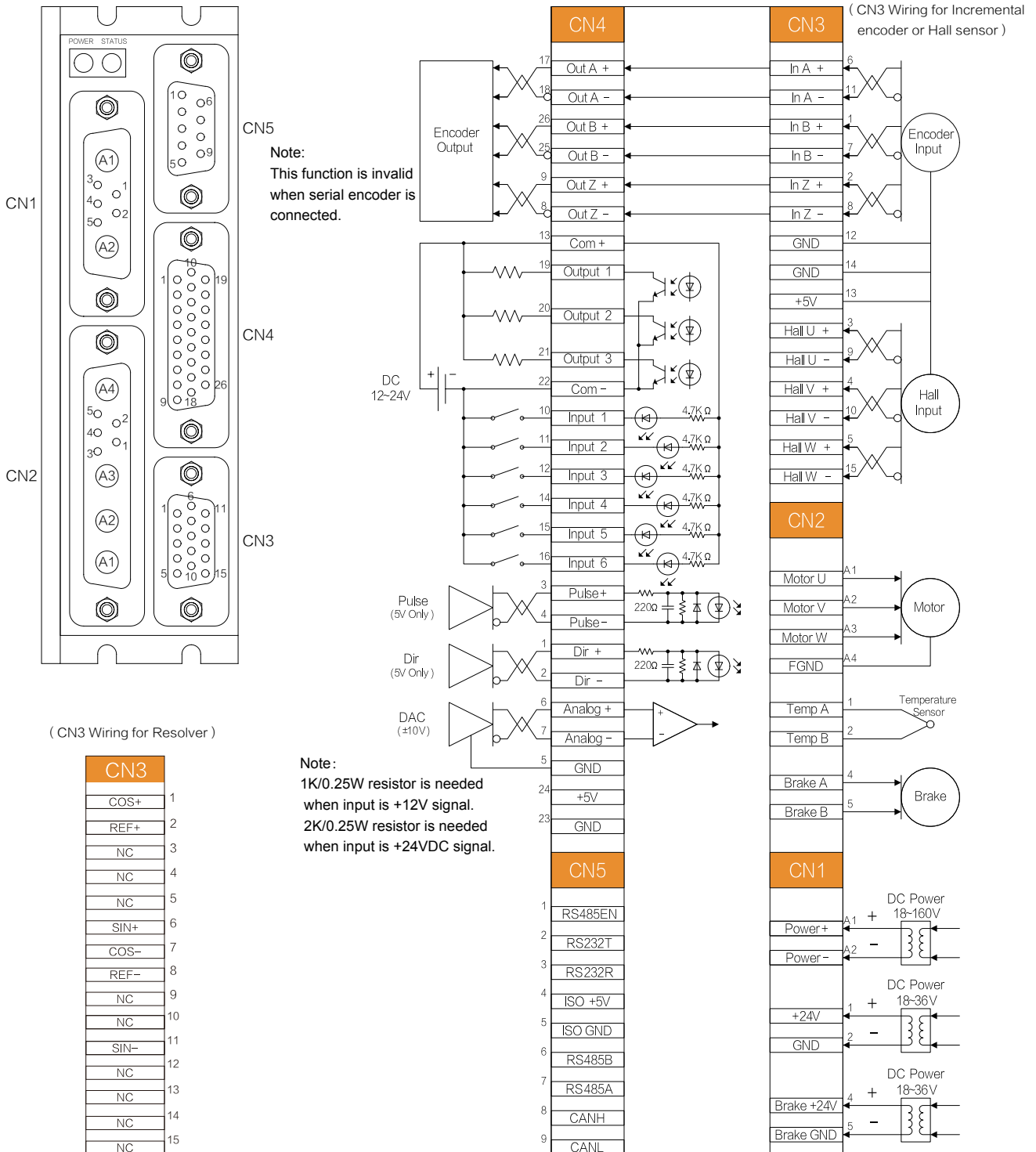

Note: For brush motor MOTOR + connected to Motor V and MOTOR - connected to Motor W

### MOTEC<sup>®</sup> Brushless DC Servo Motor Specifications

Motor Model	DSEM-J240440E40L*	Unit
Matching Driver	HBRID-3606EAX/SWLOW-3608EAX	
Rated Voltage	24.0	VDC
Rated Power	60	W
Rated Speed	4000	RPM
Max Speed	5000	RPM
Rated Torque	0.144	Nm
Rated Current	3.28	Amps
Peak Torque	0.288	Nm
Peak Current	6.56	Amps
Back EMF constant Ke	3	V/KRPM
Torque constant Kt	0.044	Nm/A
line resistor	0.68	Ω
line inductance	0.60	mH
Motor Inertia	0.072	Kgcm <sup>2</sup>
Encoder	2048 line incremental encoder	
Environment	Working Temperature: 0~50°C. Storage temperature: -25°C~70°C. Humidity: below 85%RH (no condensation) Altitude below 1000m. Outdoor (no direct sunlight). No corrosive gas. No flammable gas. No oil mist. No dust.	

### Motor Dimensions Unit : mm

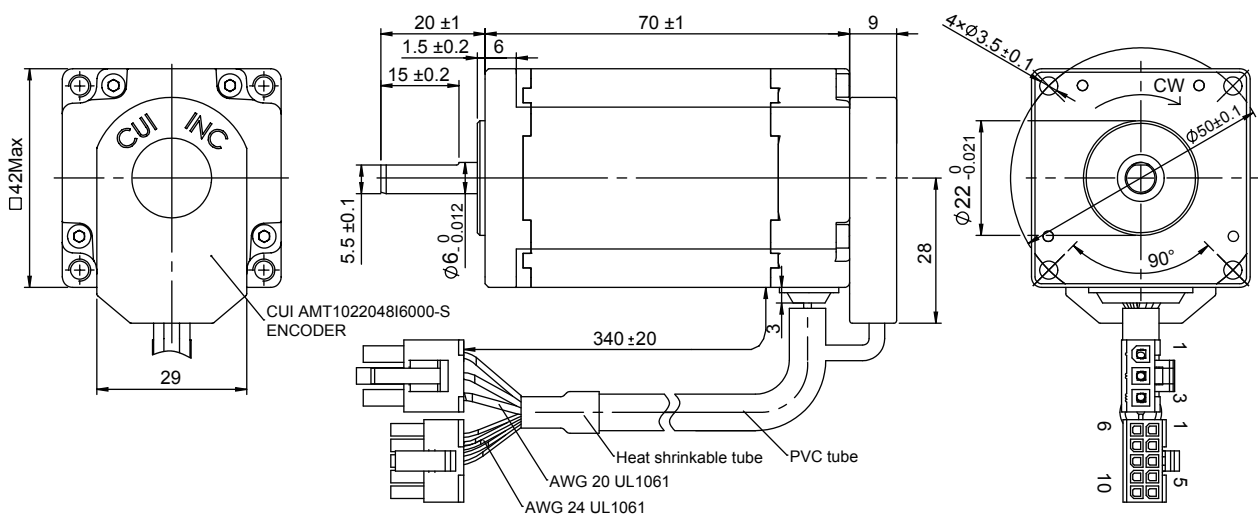

# MOTEC<sup>®</sup> Brushless DC Servo Motor

## MOTEC<sup>®</sup> Brushless DC Servo Motor Specifications

Motor Model	DSEM-J240540E40L*	Unit
Matching Driver	HBRID-3606EAX/SWLOW-3608EAX	
Rated Voltage	24.0	VDC
Rated Power	90	W
Rated Speed	4000	RPM
Max Speed	5000	RPM
Rated Torque	0.215	Nm
Rated Current	4.92	Amps
Peak Torque	0.43	Nm
Peak Current	9.84	Amps
Back EMF constant Ke	3	V/KRPM
Torque constant Kt	0.044	Nm/A
line resistor	0.40	Ω
line inductance	0.37	mH
Motor Inertia	0.114	Kgcm <sup>2</sup>
Encoder	2048 line incremental encoder	
Environment	Working Temperature: 0~50°C. Storage temperature: -25°C~70°C. Humidity: below 85%RH (no condensation) Altitude below 1000m. Outdoor (no direct sunlight). No corrosive gas. No flammable gas. No oil mist. No dust.	

Motor Dimensions Unit : mm

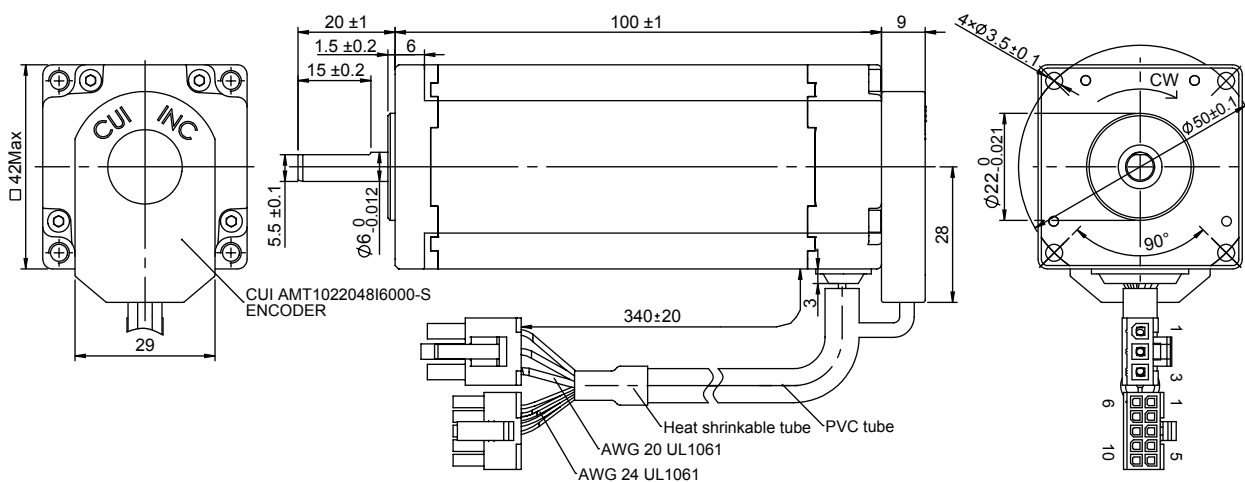

Intelligent DC Servo

### MOTEC® Brushless DC Servo Motor Specifications

Motor Model	DSEM-J240730E60L*	Unit
Matching Driver	EAGLE-4812EAX/BEAR-8015EAX	
Rated Voltage	24.0	VDC
Rated Power	0.47	Amps
Rated Speed	3000	RPM
Max Speed	5000	RPM
Rated Torque	0.32	Nm
Rated Current	7.2	Amps
Peak Torque	0.96	Nm
Peak Current	21.0	Amps
Back EMF constant Ke	4.7	V/KRPM
Torque constant Kt	0.0448	Nm/A
Phase Resistor Rt	0.53	Ohms(@20°C)
Motor Inertia	0.10	Kgcm <sup>2</sup>
Encoder	2500ppr incremental encoder. Other feedback optional.	
Environment	Working Temperature: 0~40°C. Storage temperature: -20°C~65°C. Humidity: 20% - 85%RH (no condensation) Altitude below 1000m. Vibration below 49m/s <sup>2</sup>	

### Motor Dimensions Unit : inch/mm

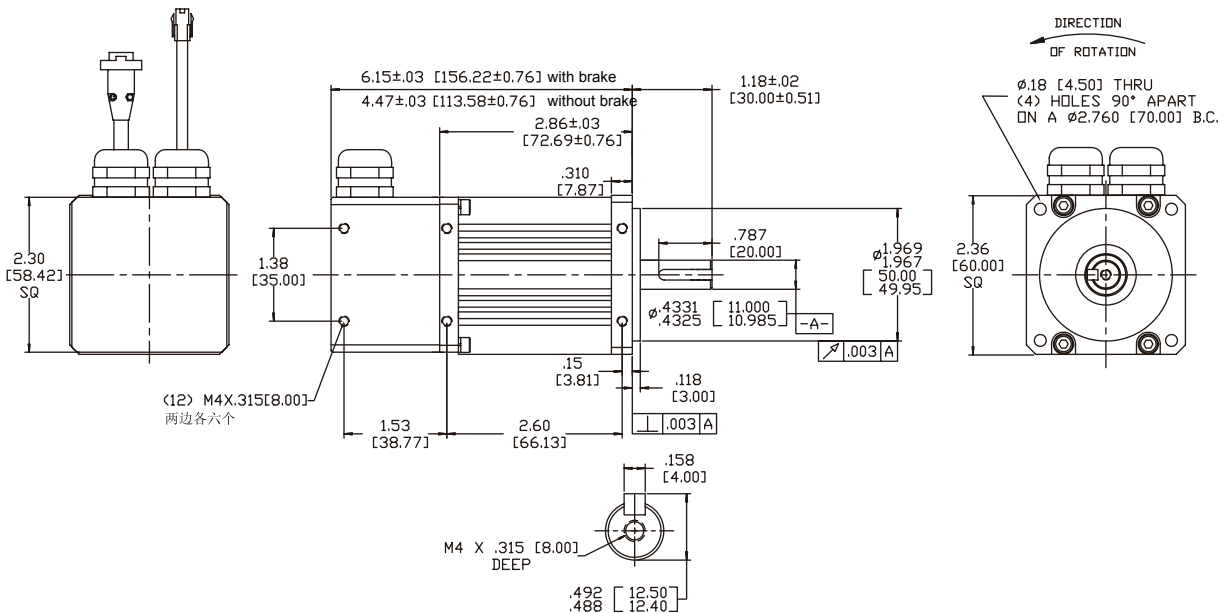

# MOTEC<sup>®</sup> Brushless DC Servo Motor

## MOTEC<sup>®</sup> Brushless DC Servo Motor Specifications

Motor Model	DSEM-J241218E60L*	Unit
Matching Driver	EAGLE-4812EAX/BEAR-8015EAX	
Rated Voltage	24.0	VDC
Rated Power	0.33	Amps
Rated Speed	1800	RPM
Max Speed	2600	RPM
Rated Torque	1.06	Nm
Rated Current	12.1	Amps
Peak Torque	3.0	Nm
Peak Current	36	Amps
Back EMF constant Ke	8.9	V/KRPM
Torque constant Kt	0.0848	Nm/A
Phase Resistor Rt	0.63	Ohms(@20°C)
Motor Inertia	0.134	Kgcm <sup>2</sup>
Encoder	2500ppr incremental encoder. Other feedback optional.	
Environment	Working Temperature: 0~40°C. Storage temperature: -20°C~65°C. Humidity: 20% - 85%RH (no condensation) Altitude below 1000m. Vibration below 49m/s <sup>2</sup>	

Motor Dimensions Unit : inch/mm

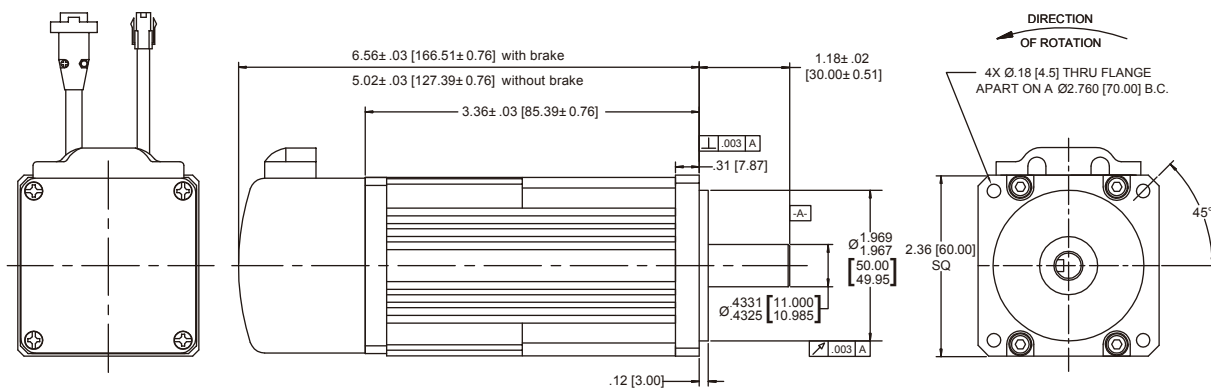



# MOTEC<sup>®</sup> Brushless DC Servo Motor

## MOTEC<sup>®</sup> Brushless DC Servo Motor Specifications

Motor Model	DSEM-J480240E40L*	Unit
Matching Driver	EAGLE48-12EAX	
Rated Voltage	48.0	VDC
Rated Power	60	W
Rated Speed	4000	RPM
Max Speed	5000	RPM
Rated Torque	0.144	Nm
Rated Current	1.63	Amps
Peak Torque	0.288	Nm
Peak Current	3.26	Amps
Back EMF constant Ke	6	V/KRPM
Torque constant Kt	0.088	Nm/A
Line resistor	2.62	Ω
Line inductance	2.50	mH
Motor Inertia	0.072	Kgcm <sup>2</sup>
Encoder	2048 line incremental encoder	
Environment	Working Temperature: 0~50°C. Storage temperature: -25°C~70°C. Humidity: below 85%RH (no condensation) Altitude below 1000m. Outdoor (no direct sunlight). No corrosive gas. No flammable gas. No oil mist. No dust.	

Motor Dimensions Unit : mm

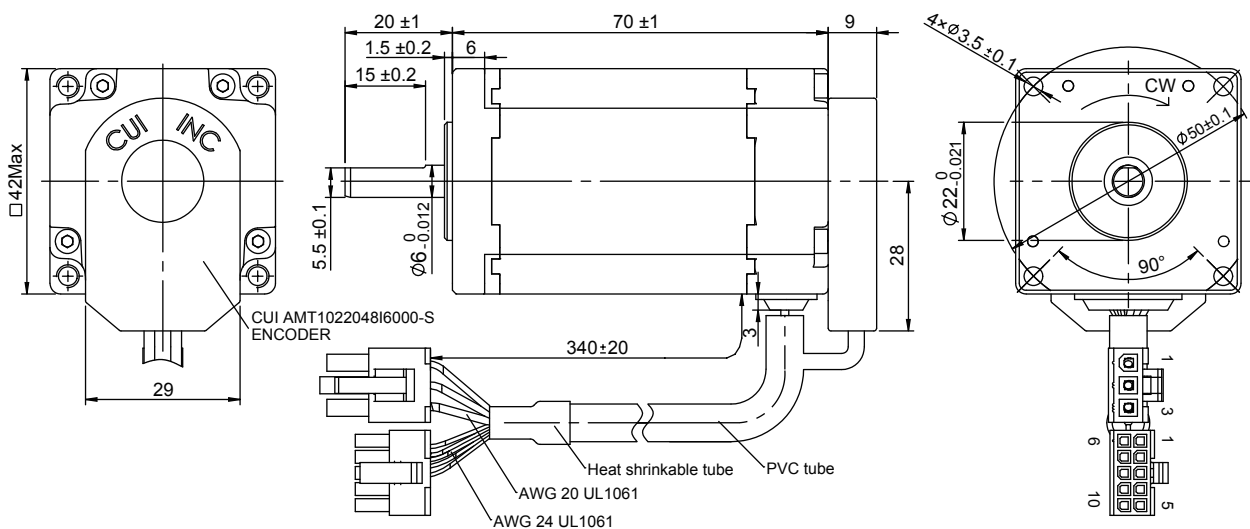

### MOTEC® Brushless DC Servo Motor Specifications

Motor Model	DSEM-J480340E40L*	Unit
Matching Driver	EAGLE48-12EAX	
Rated Voltage	48.0	VDC
Rated Power	90	W
Rated Speed	4000	RPM
Max Speed	5000	RPM
Rated Torque	0.215	Nm
Rated Current	2.40	Amps
Peak Torque	0.43	Nm
Peak Current	4.80	Amps
Back EMF constant Ke	6.10	V/KRPM
Torque constant Kt	0.089	Nm/A
Line resistor	1.47	Ω
Line inductance	1.57	mH
Motor Inertia	0.114	Kgcm <sup>2</sup>
Encoder	2048 line incremental encoder	
Environment	Working Temperature: 0~50°C. Storage temperature: -25°C~70°C. Humidity: below 85%RH (no condensation) Altitude below 1000m. Outdoor (no direct sunlight). No corrosive gas. No flammable gas. No oil mist. No dust.	

Motor Dimensions Unit : mm

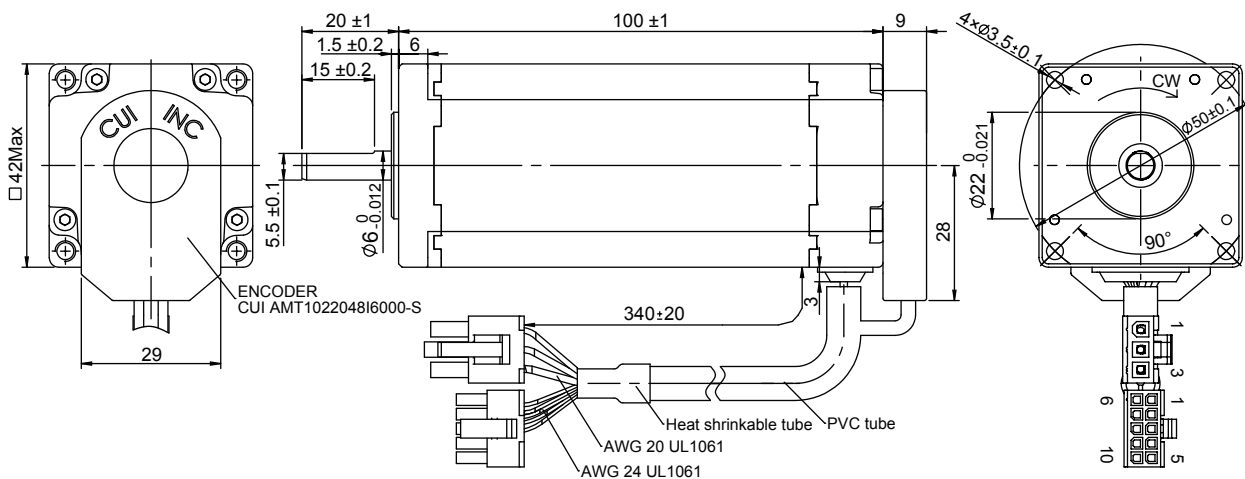

# MOTEC<sup>®</sup> Brushless DC Servo Motor

## MOTEC<sup>®</sup> Brushless DC Servo Motor Specifications

Motor Model	DSEM-J480830E60L*	Unit
Matching Driver	EAGLE-4812EAX/BEAR-8015EAX	
Rated Voltage	48.0	VDC
Rated Power	0.34	Amps
Rated Speed	3000	RPM
Max Speed	4000	RPM
Rated Torque	0.91	Nm
Rated Current	8.4	Amps
Peak Torque	2.7	Nm
Peak Current	25.0	Amps
Back EMF constant Ke	11.4	V/KRPM
Torque constant Kt	0.1089	Nm/A
Phase Resistor Rt	1.02	Ohms(@20°C)
Motor Inertia	0.1335	Kgcm <sup>2</sup>
Encoder	2500ppr incremental encoder. Other feedback optional.	
Environment	Working Temperature: 0~40°C. Storage temperature: -20°C~65°C. Humidity: 20% - 85%RH (no condensation) Altitude below 1000m. Vibration below 49m/s <sup>2</sup>	

Motor Dimensions Unit : inch/mm

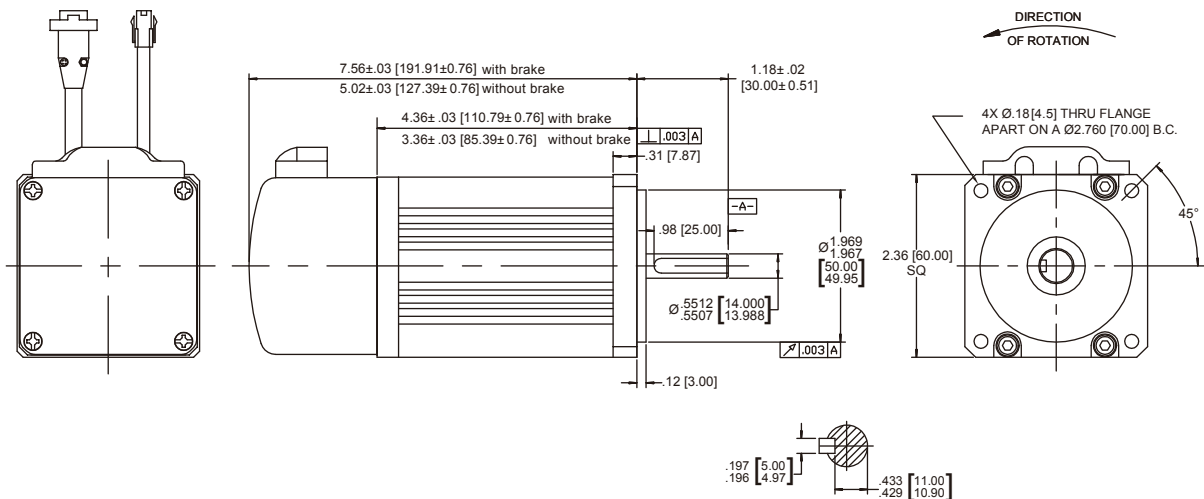



# MOTEC<sup>®</sup> Brushless DC Servo Motor

## MOTEC<sup>®</sup> Brushless DC Servo Motor Specifications

Motor Model	DSEM-J482030E90L*	Unit
Matching Driver	HIPPO-8020EAX/ELPHT-8030EAX	
Rated Voltage	48.0	VDC
Rated Power	2.43	Amps
Rated Speed	3000	RPM
Max Speed	3300	RPM
Rated Torque	2.4	Nm
Rated Current	20	Amps
Peak Torque	6.0	Nm
Peak Current	50.0	Amps
Back EMF constant Ke	14.48	V/KRPM
Torque constant Kt	0.1214	Nm/A
Phase Resistor Rt	0.39	Ohms(@20°C)
Motor Inertia	0.6538	Kgcm <sup>2</sup>
Encoder	2500ppr incremental encoder. Other feedback optional.	
Environment	Working Temperature: 0~40°C. Storage temperature: -20°C~65°C. Humidity: 20% - 85%RH (no condensation) Altitude below 1000m. Vibration below 49m/s <sup>2</sup>	

Motor Dimensions Unit : inch/mm

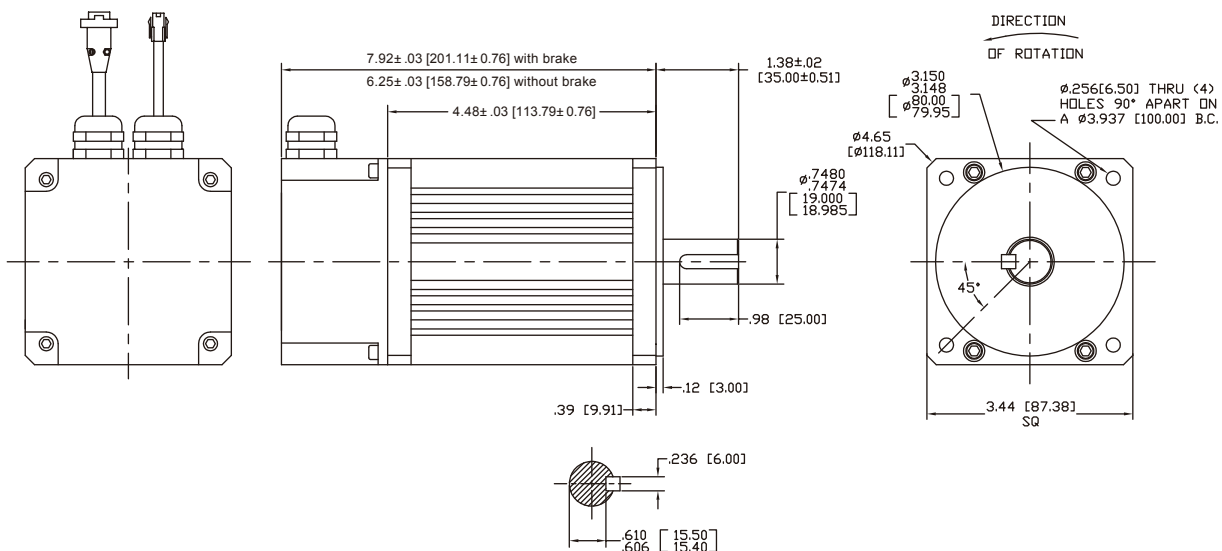

Intelligent DC Servo



# MOTEC<sup>®</sup> DC Servo Motor System Accessories

## MOTEC DC Servo Motor Power Cable

Below diagram applied to DC servo motor and driver supplied by MOTEC. Third party DC servo motor may have different assignment. Please check with motor manufacturer.

### 42 size motor power cable pin assignment

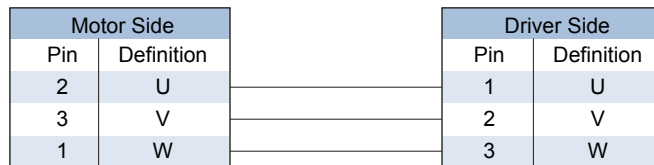

### 60/90/120 size motor power cable pin assignment



## Encoder Cable - Incremental

### 42 Size Motor Encoder Cable Pin Assignment

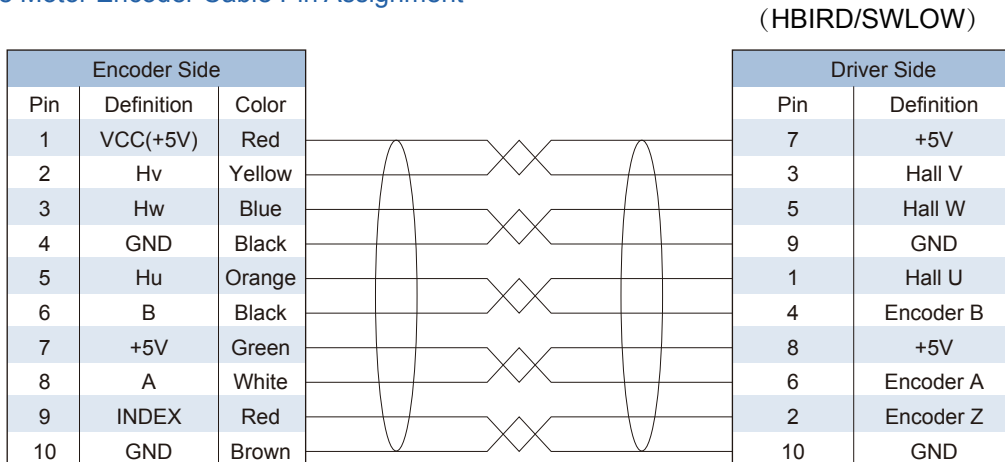

(EAGLE)

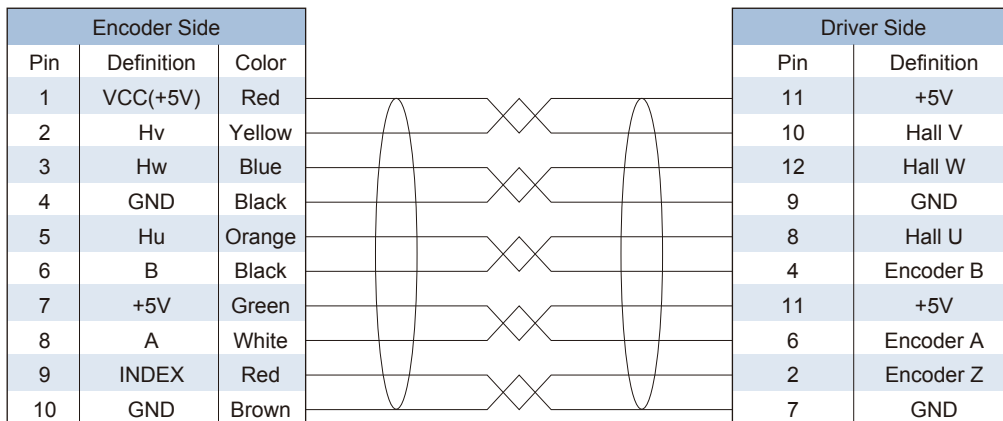

### 60/90/120 Size Motor Encoder Cable Pin Assignment

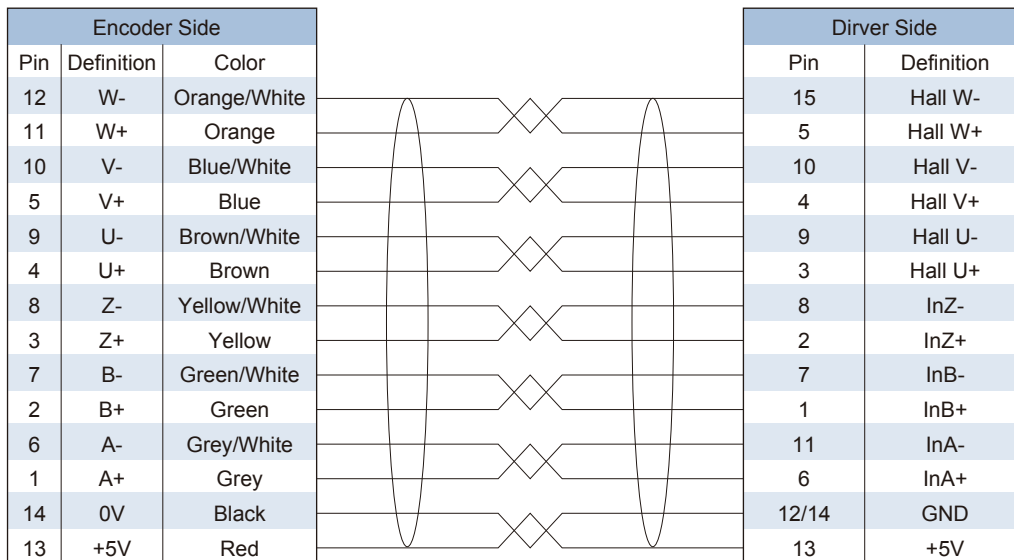

# MOTEC<sup>®</sup> DC Servo Motor System Accessories

## Communication Cable

### Cable between driver and host station

Cable Model	Description
MCDC-PD1-LXXX	RS232 communication cable with DB9 connector and MD connector, suitable for BEAR/HIPPO driver and other host station with RS232 interface.

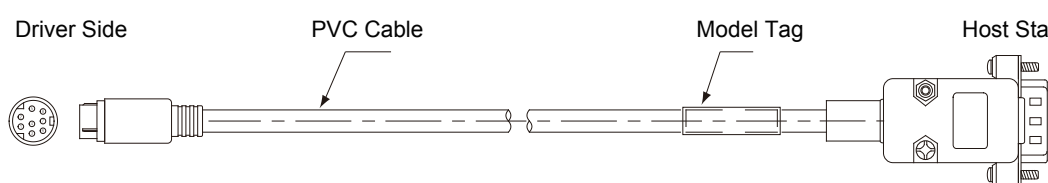

The diagram illustrates the MCDC-PD1-LXXX cable. On the left, the 'Driver Side' features a DB9 connector. This is followed by a section of 'PVC Cable'. A 'Model Tag' is attached to the cable. On the right, the 'Host Station' is connected via an MD connector.

Cable Model	Description
MCDC-PD0-LXXX	RS232/RS485/CAN Bus communication cable with MD8 connector and open wires. Suitable for BEAR/HIPPO driver

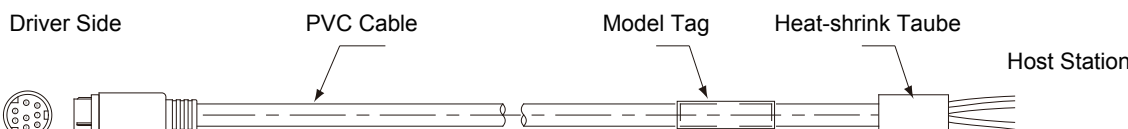

The diagram illustrates the MCDC-PD0-LXXX cable. On the left, the 'Driver Side' features a DB9 connector. This is followed by a section of 'PVC Cable'. A 'Model Tag' is attached to the cable. On the right, a 'Heat-shrink Taube' (heat-shrink tube) covers the 'Host Station' area, which has open wires.

### Cable between drivers

Cable Model	Description
MCDC-DD-LXXX	RS232/RS485/CAN Bus communication cable with MD8 connector on both ends. Suitable for BEAR/HIPPO driver for network operation.

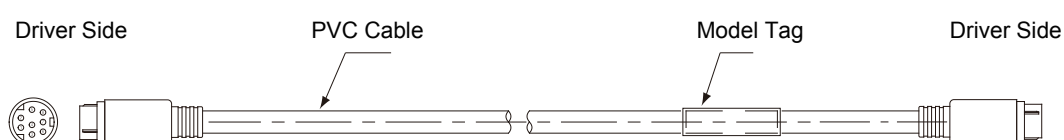

The diagram illustrates the MCDC-DD-LXXX cable. On the left, the 'Driver Side' features a DB9 connector. This is followed by a section of 'PVC Cable'. A 'Model Tag' is attached to the cable. On the right, another 'Driver Side' is shown with an MD8 connector.

#### PC Communication Cable

Cable Model	Description
CABLE-232-USB-MD8-1200	USB to RS232 cable with USB connector and MD8 (RS232) connector. Suitable for BEAR/HIPPO driver, 1.2m long.

Cable Model	Description
CABLE-485-USB-MD8-2000	USB to RS485 cable with USB connector and MD8(RS485) connector. Suitable for BEAR/HIPPO drivers, 2m long.

Cable Model	Description
CABLE-Mini USB-1000	USB communication cable. Suitable for HBIRD driver. 1m long.

# MOTEC<sup>®</sup> DC Servo Motor System Accessories

## Customized Servo/Stepper System Designing & Manufacturing

MOTEC R&D team has been providing customized servo and stepper system for nearly 10 years and many of our customized products have been working in various of industries including aviation, military, special testing&measuring, maritime, automobile etc across asia pacific area. Below is a list of what we designed and manufactured for our customers in the past as reference.

- Extremely low working temperature(as low as - 40°C)
- Customized working voltage and current
- Special water proof casing IP67
- Super small servo/stepper driver products
- Driver integrated with motor products
- Multi-Axis servo/stepper driver in one casing
- Speical control functions
- Speical control Bus
- More I/O ports
- PCB drivers without casing

## Examples: Customized designed military class servo drivers



Dual Axis Military Class Servo Driver

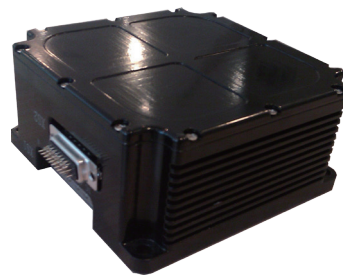

Single Axis Military Class Servo Driver

- Total solution with military class gearbox and servo motor
- 18VDC~160VDC power supply. Peak current 100A.
- Support incremental encoder, Hall sensor and resolver.
- Working temperature - 40. C ~ 70. C
- Water and dust proof. Anti-shock prorection.
- RS232/RS485/CAN Bus.
- Network/Analog/Pulse/Standalone operation modes.
- Position/speed/torque control modes.
- Various of internal test and protections.
- Motor temerature monitoring and protection
- Dedicated motor brake interface.
- 8 digital input, 3 digital output, 1 analog input.

- Stepper System
- AC Servo System
- Electric Cylinder
- Servo Wheel System
- 5+ Axis CNC
- Planetary Gearbox

### MOTEC® Stepper System

MOTEC® Stepper system comes with standard models and intelligent models for customer's choice. The maximum resolution of standard stepper system is up to 60000P/R which can be setup with a 8-position dip switch and two power supply options are available, which is 18~80VDC and 150~260VAC. Intelligent stepper drivers are equipped with RS232/RS485/CAN communication ports and I/O ports as well and compatible with MODBUS & CANOPEN protocols. MOTEC intelligent steppers can be configured to work in network model and each of the drivers can have its own pre-programmed software running simultaneously and velocity generation can be set up each respectively.

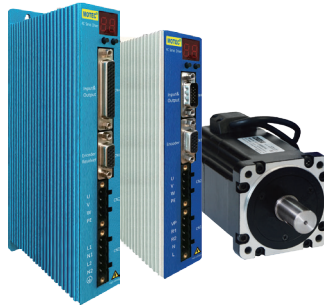

### MOTEC® β AC Servo System

MOTEC® β Series AC Servo System have three types for customer's choice including Full Function Model, Standard Model and High Performance Model, which features high power density and compact size. MOTEC® β Series AC Servo System covers power range from 50W to 3KW and compatible with MOTEC® servo motors, Panasonic servo motors, Tamagawa servo motors. MOTEC® β Series AC Servo system features integrated PLC function, CAN bus compatible and servo motors support 2500PPR encoder, 23 bit single turn/multi-turn absolute encoder and resolver.

### MOTEC® Electric Servo Cylinder

MOTEC® Electric Servo Cylinder is an integration of servo motor and lead screw and it converts servo motors precise rotary motion to precise linear motion. MOTEC electric servo cylinder features high transmission efficiency, high resolution high reliability and safety, easy for maintenance, very low noise and long product life etc and it has been widely used in many industries including robots, laboratory equipments, welding machines, aviation testing equipments multi-axis simulator, valve control, CNC and multidimensional cinema etc.

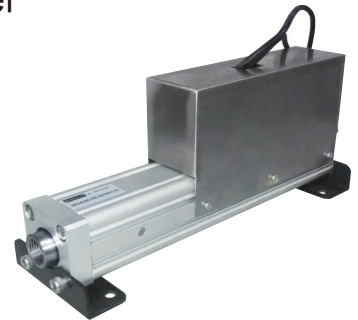

## MOTEC<sup>®</sup> Product Family Members Overview

### MOTEC<sup>®</sup> Servo Wheel System

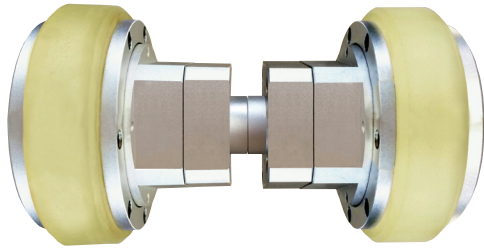

MOTEC<sup>®</sup> Servo Wheel is an innovated products developed by MOTEC (China) with its own IP. It is a cutting edge product which is an integration of servo driver, motion controller and a creative mechelectric design, which is a idea for intelliegent warehouse, AGV and robot applications with value for money features. MOTEC Servo Wheel System is equipped with custom-designed MOTEC<sup>®</sup> high performance servo drivers to achieve its best performance and reliability.

### MOTEC<sup>®</sup> 5+ Axis CNC

MOTEC<sup>®</sup> 5+ axis CNC is an extremely powerful and open CNC system which can control eight axis simultaneously either in single chanel mode or multi-channel mode. It supports pluse/direction control mode, network control mode(compatiable with various of bus&protocals) with integrated PLC function. It comes with powerful program software with which users can use standard G code and M function to build up their own application easily. Users can even order custom designed user-interface software from MOTEC though the standard one is a user-friendly graphic interface. The system features very short interpolation period, visiable PID setting function, electronic CAM etc.



### MOTEC<sup>®</sup> Planetary Gearbox

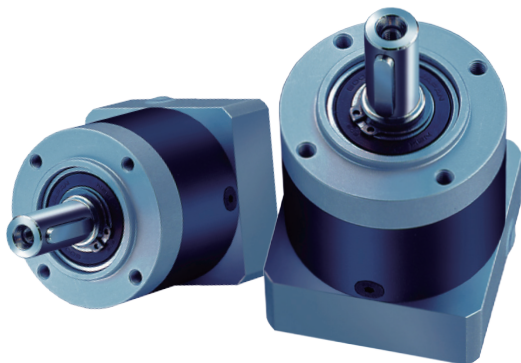

Planetary Gearbox is widely used high precision device designed to increase outport torque and reduce equivalent moment of inertia by reducing rotating speed with high efficiency(over 96%). MOTEC has developed hundres of models under four series over the decades and tens of thousands MOTEC gearbox have been used in various industriesincluding aviation,CNC,welding, cutting, packing, printing. MOTEC planetary gearbox has economy and high precision models for customer's choice. Custom designed planetary gearbox is also available ie higher or lower woking temperature, special flange size, key input, double shafts,anchorbolt installtion, higher resolution etc.

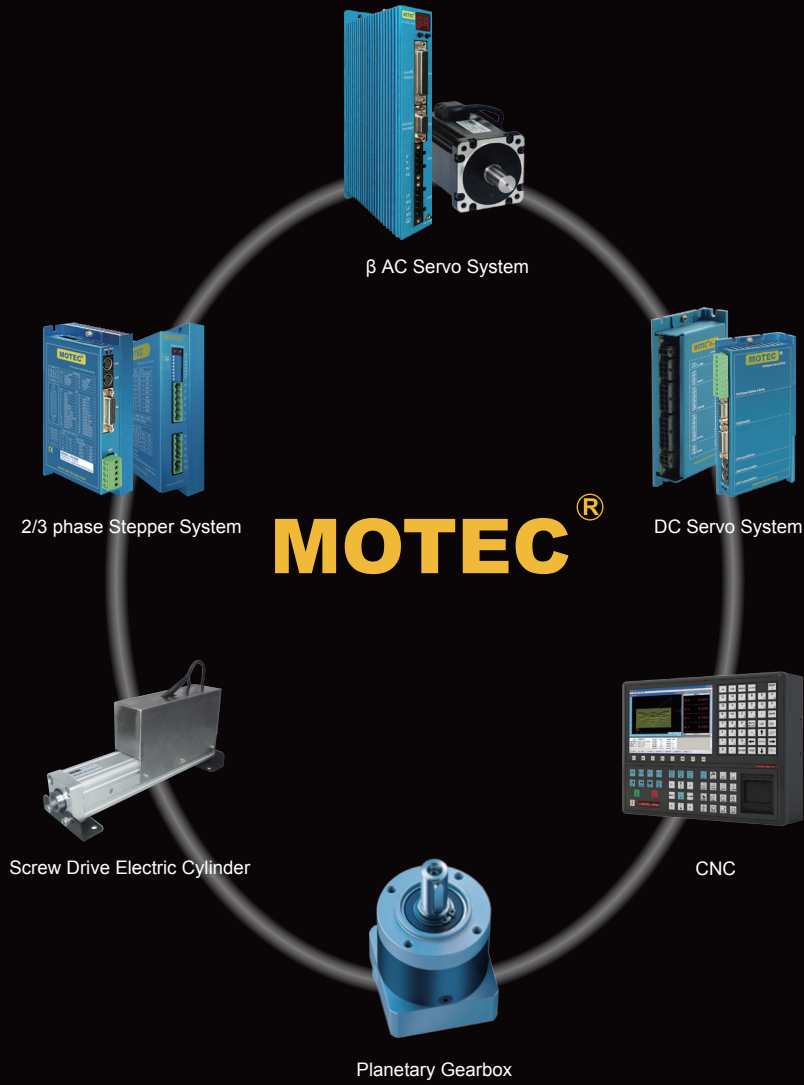

# NORTION

Nortion Servo Technology (Beijing) Co.,Ltd.

Address: 11B, No.17 Huan Ke Zhong Lu, Tongzhou District  
Beijing, P.R.C. 101102

**A MOTEC Group Company**



Wechat Users Please Scan for More Information