

# SMB100 - 6 Nm

Tolleranze generali: UNI ISO 2768 - f

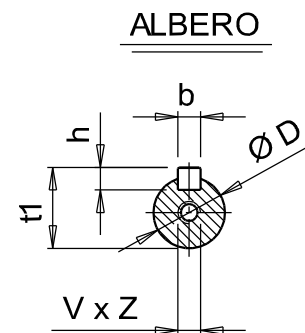
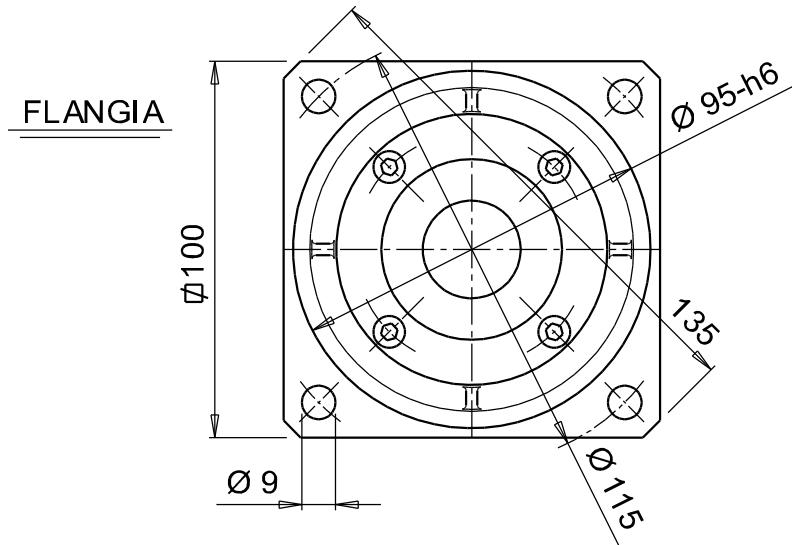
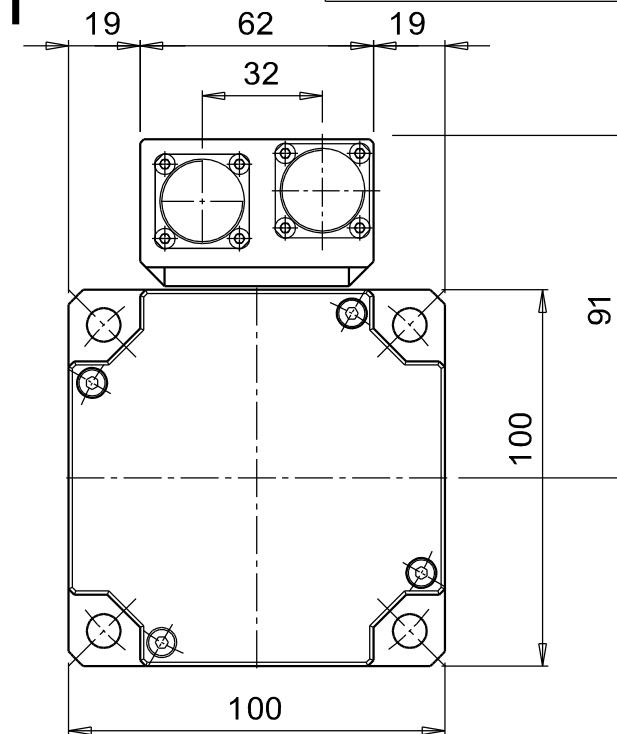
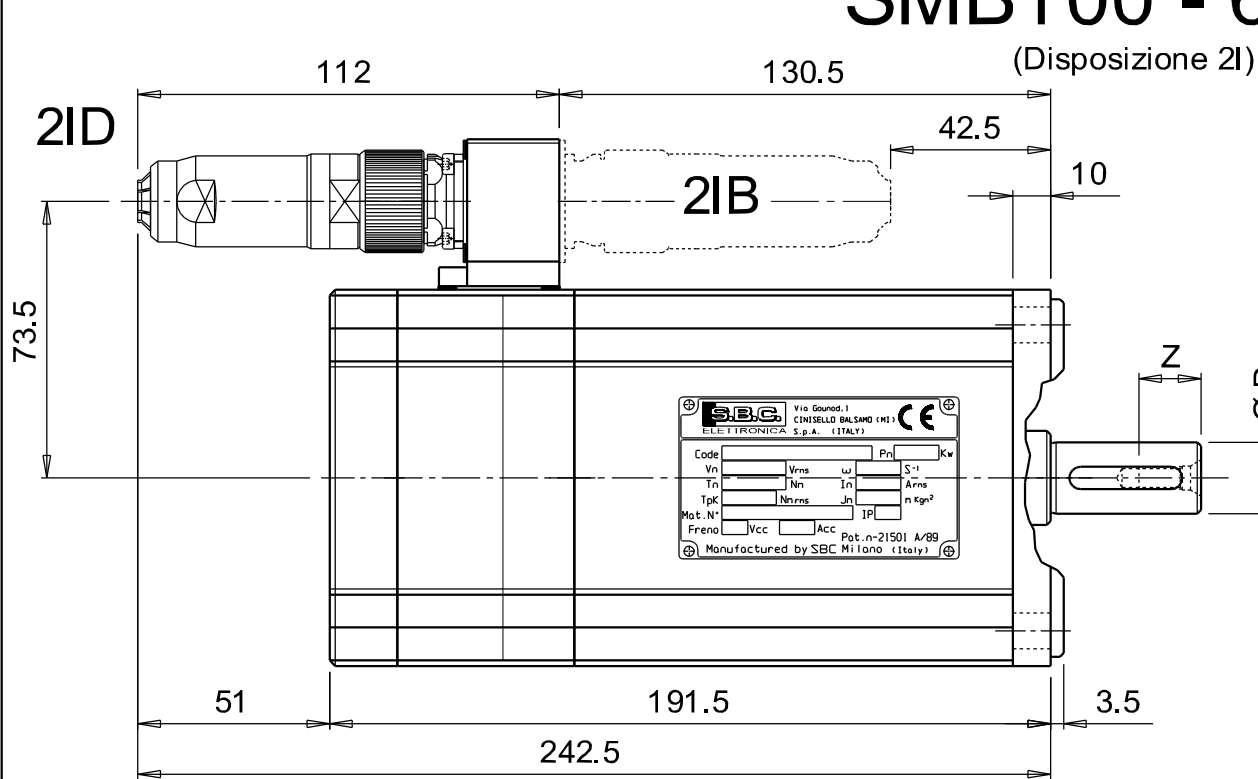

DIMENSIONI ALBERO							
Pos.*	C x D	b x h	t1	V x Z			
1	40 19	6 6	21.5	M6	16		
2	50 24	8 7	27	M8	19		

\* E' il numero di identificazione del tipo di albero desiderato per l'ordinazione del motore. Seguito dalla "S" significa senza linguetta

MODIFICHE	Data	Revisione	Descrizione	Eseg. da	Control.

Nome del file: \N\SMB\Quote d'ingombro\100\QISMB100\_D2I

S.p.A.  
Via Gounod, 1  
CINISELLO B. (MI)  
( ITALY )

Denominazione: QUOTE D' INGOMBRO  
Motore tipo: SMB 100 - 6 Nm

Scalo	Data	Firma
-	28/06/01	
	28/06/01	
Modif. to	--	REV.0

DIS. QISMB100\D2I