

All Dimension Must Be Held Within Unless otherwise noticed (mm/inch)  
 FINAL TOLERANCE REFERENCE  
 GB/T 1804-m Unit:mm  
 LINER ≤6 ±0.1 >6~30 ±0.2  
 >30~120 ±0.3 >120~400 ±0.5

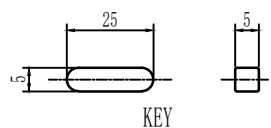
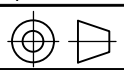

序号	定义	颜色
1	MOTOR U	白 WHITE
2	MOTOR V	红 RED
3	MOTOR W	黑 BLACK
4	MOTOR PE	黄绿 YEL/GRN

电源线 (8AWG) Power Wire

角号 PIN	定义 FUNCTION	颜色 COLOR	线径 WIRE GAGE	角号 PIN	定义 FUNCTION	颜色 COLOR	线径 WIRE GAGE
1	GND	黑 BLACK	28AWG	9	NC	NC	28AWG
2	DC +5V	红 RED		10	/W	白黑 WHT/BLK	
3	W	白 WHITE		11	/V	灰黑 GRY/BLK	
4	V	灰 GRAY		12	/U	棕黑 BRN/BLK	
5	U	棕 BROWN		13	/Z	黄黑 YEL/BLK	
6	Z	黄 YELLOW		14	/B	绿黑 GRN/BLK	
7	B	绿 GREEN		15	/A	蓝黑 BLU/BLK	
8	A	蓝 BLUE					

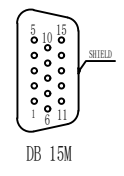

DB 15M

反馈线 Feedback Wire

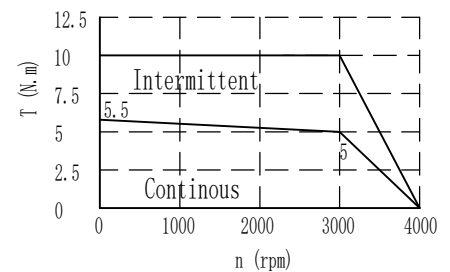
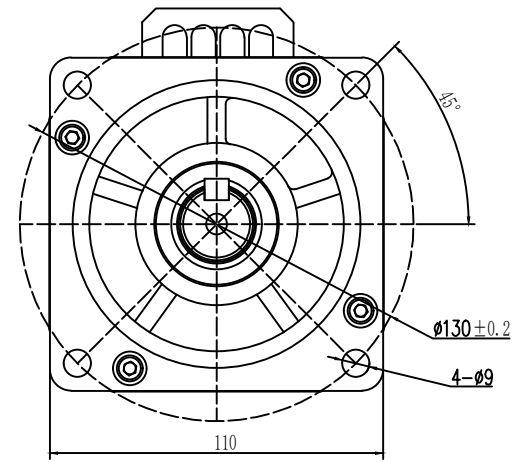
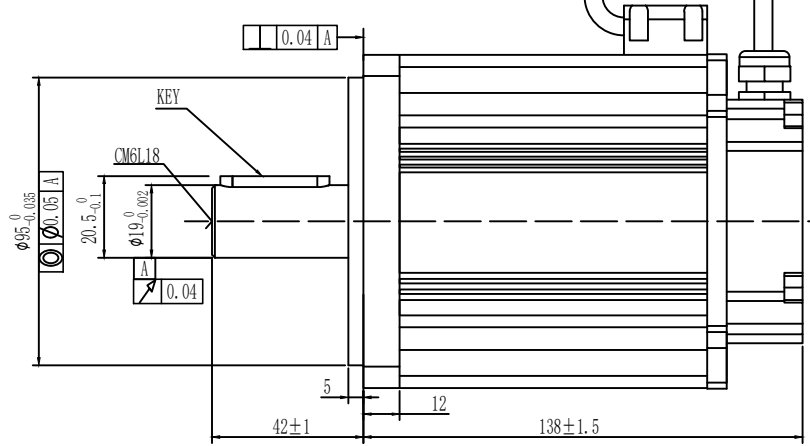
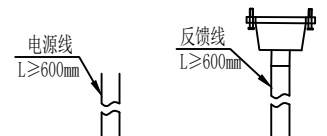

极数 No. of poles	10	线电阻 Resistance line-line $R_L$ ( $\Omega$ )	0.012
母线电压 DC Link Voltage $U_{dc}$ (V)	48	线电感 Inductance line-line $L_L$ (mH)	0.40
额定功率 Rated Power $P_N$ (W)	1550	反电势常数 Voltage constant $K_e$ (V/krpm)	8.0
额定转矩 Rated Torque $T_N$ (N.m)	5	转矩常数 Torque constant $K_t$ (Nm/A)	0.13
额定转速 Rated Speed $n_N$ (rpm)	3000	转动惯量 Rotor moment of inertia $J_m$ (Kg.cm)	7
额定电流 Rated Current $I_N$ (A)	45	最大径向力 Max. radial force $F_r$ (N)	1176
最大转矩 Maximum torque $T_s$ (N.m)	10	最大轴向力 Max. axial force $F_a$ (N)	392
最大电流 Maximum Current $I_s$ (A)	90	反馈装置 Feed back device	Incremental 2500ppr Magnetic Encoder
连续静态转矩 Standstill torque $T_s$ (N.m)	5.5	绝缘等级 Insulation class	F
连续静态电流 Standstill Current $I_s$ (A)	50	防护等级 Protection level	IP65
电气时间常数 Electrical time constant $\tau_e$ (ms)	33	重量 Weight	4.2
机械时间常数 Mechanical time constant $\tau_m$ (ms)	0.7	工作环境温度 Operating temperature ( $^{\circ}C$ )	-40~+50

VER #	ECN #	Change description	Name	Date
		Title	ACL1101550F5-2500M-48-19	
Controlled	Name	Date	PN.	
Drawn by	LYS	24.03.09	Page 1 of 1	Material
Checked by	ZH	24.03.09	Weight	VER # 1.0
Approved by	ZJC	24.03.09	Drawing #	