

# 伺服电机规格书

## PMSM SPECIFICATION

电机型号: 60BM-R6430A5-CB  
MODEL:

版本号: HN

### 基本参数/BASIC PARAMETERS

额定功率(Kw): Rated Output(Kw):	0.2	极数: Number of Poles:	10
额定电压(V): Rated Voltage(V):	DC24	耐热等级: Vibration Class :	F
额定转速(rpm): Rated Speed(rpm):	3000	最高转速(rpm): Max. Speed(rpm):	3200
额定电流(Arms): Rated Current(Arms):	10.5±10%	瞬时最大电流(Arms): Instantaneous Max. Current(Arms):	21±10%
额定扭矩(N.m): Rated Torque(N.m):	0.64	瞬时最大扭矩(N.m): Instantaneous Peak Torque(N.m):	1.28
线电阻(Ω): Line Resistance(Ω):	0.169±10%(25℃)	线电感(mH): Line Inductance(mH):	0.448±10%
线反电势(V/krpm): Line Back EMF.(V/krpm):	3.7±10%	力矩系数(N.m/A): Torque Coefficient(N.m/A):	0.06±10%
转子惯量(Kg.m <sup>2</sup> ×10 <sup>-4</sup> ): Rotor Moment of Inertia(Kg.m <sup>2</sup> ×10 <sup>-4</sup> ):	0.32±10%	反馈元件: Feedback Component:	磁电增量式/Incremental Encoder, 2500PPR
保持制动器扭矩(N.m): Static Torque(N.m):	>1	保持制动器工作电压(V): Rated Voltage(V):	DC24V 0.4A
绝缘电阻(MΩ): Insulation Resistance(MΩ):	DC500V, >20MΩ	噪音(dB): Noise(dB):	≤60dB, 无异响/None Special Noise
工作时间: Time rating :	连续 Continuous	振动等级: Vibration Class :	V 15
环境温度: /Ambient Temperature :	-20~+40℃	环境湿度: Ambient Humidity :	20~80%不结露 20~80% No Condensation
励磁方式: Excitation:	永磁式 Permanent Magnet	安装方式: Mounting :	法兰式 Flange Method
连接方式: Drive Method :	直接连接 Direct Drive	电机重量(Kg): Weight(Kg):	1.35
保护方式: Enclosure :	全封闭, 自冷IP54(IP65 可选)(轴贯通部分除外) Totally Enclosed, Self-cooled, IP54(IP65 optional)(except for shaft opening).		
旋转方向: Rotation Direction :	正转指令从负载侧看为逆时针方向旋转 Counterclockwise(CCW)		

※额定转矩表示安装在200×200×6的铝制散热板上且在环境温度40℃时的连续容许转矩值。/Rated torque is the continuous allowable torque at 40℃ with an Al heatsink of 200×200×6.

### 连接器/CONNECTORS

#### 动力插座/Power Line Socket

颜色 colour	黄绿	红	蓝	黑	细红	细黑
信号引线 Signal leads	PE	U	V	W	24V	BRK

#### 编码器插座/Encoder Socket(DB15 PIN 公头)

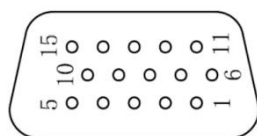

插座编号 Socket Numbers	1	2	3	4	5	6	7	8	9	10	11	12	13	14	15
颜色 colour			棕	红	黑	灰	黄黑	黄	白		绿黑	绿	蓝黑	蓝	
信号引线 Signal leads			U+	5V	0V	V+	Z-	Z+	W+		B-	B+	A-	A+	

# 伺服电机规格书

## PMSM SPECIFICATION

编码器零点与电机相位关系

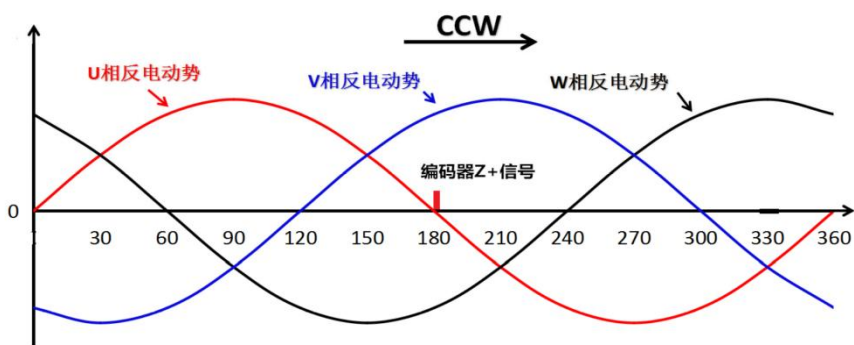

### 转矩—转速特性/TORQUE-SPEED CHARACTERISTICS

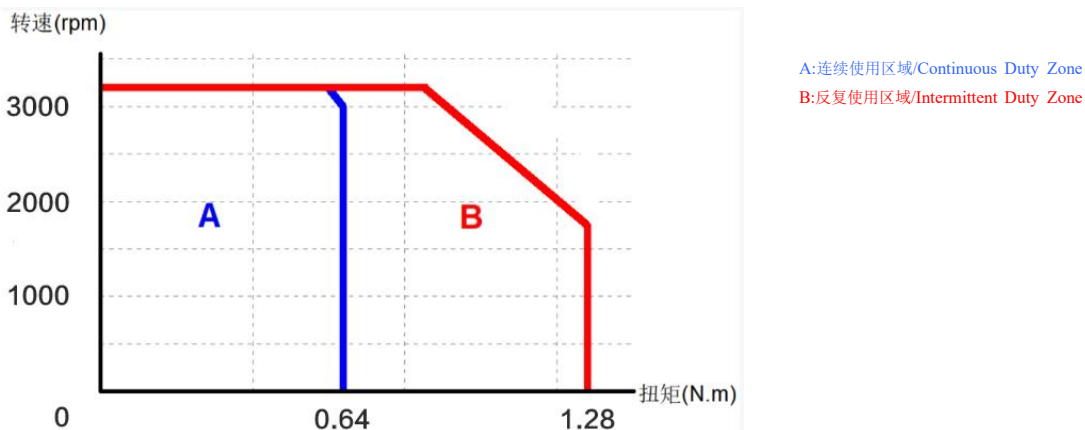

### 过载特性曲线/OVERLOAD CHARACTERISTICS

工作时间在电机环境温度40℃以及热起动的条件下设定/The characteristics is measured in the warm-boot conditions at 40℃:

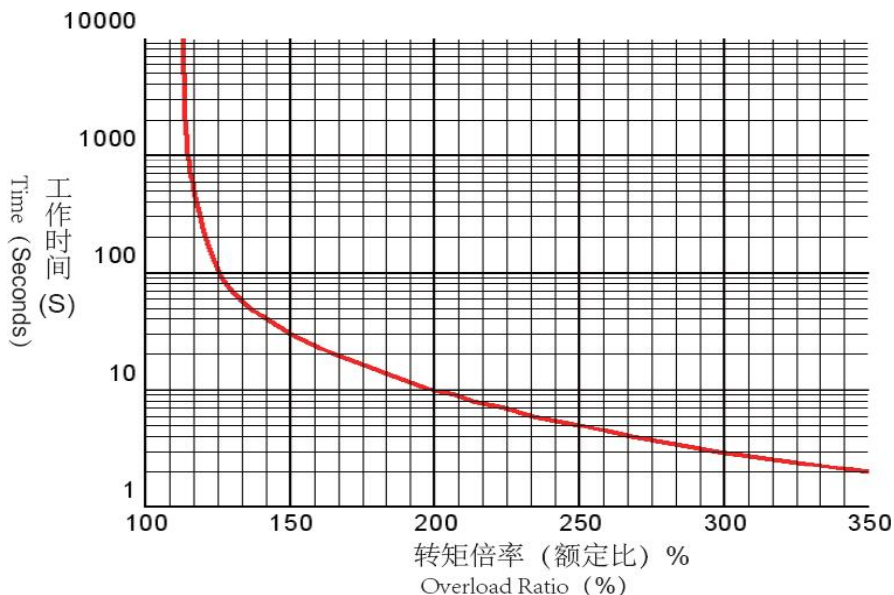

※1:上述过载特性并不保证100%以上输出的连续使用/The above characteristics do not supply 100% output for continuous running;

※2:使用时, 请确保有效转矩在“转矩-转速特性”的连续使用范围内/Please make sure that the effective torque is in the range of T-N characteristics' continuous duty zone.

※3:由于产品改良或规格变更, 我们会适时对规格书进行更新, 请关注相关信息, 恕不另行通知。/Specification are subject to change without notice for ongoing product modification and improvement, please pay more attentions to the related information.

# 电机外形参考图形

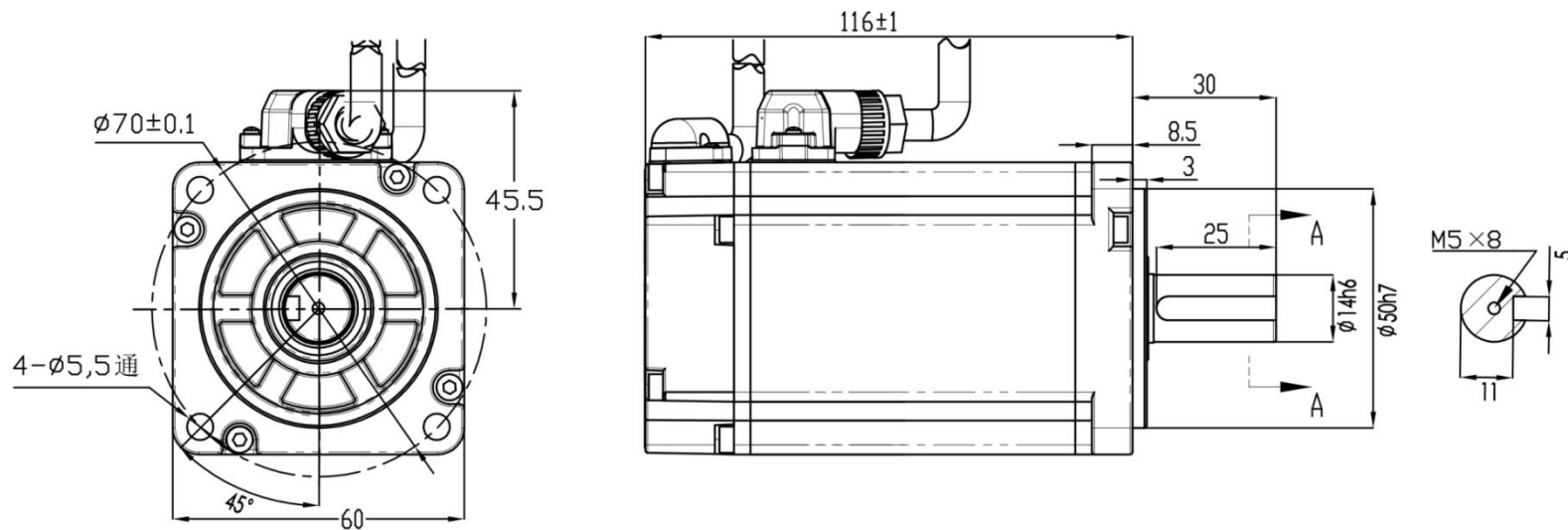

设计 变更	4		视图		设计:	日期:	名称: 高性能稀土永磁伺服电机	订货号:
	3				校对:	日期:		
	2		ERP:		批准:	日期:	型号:	
	1							