

TFR motor mounting dimensions
TFR規格外形安裝尺寸

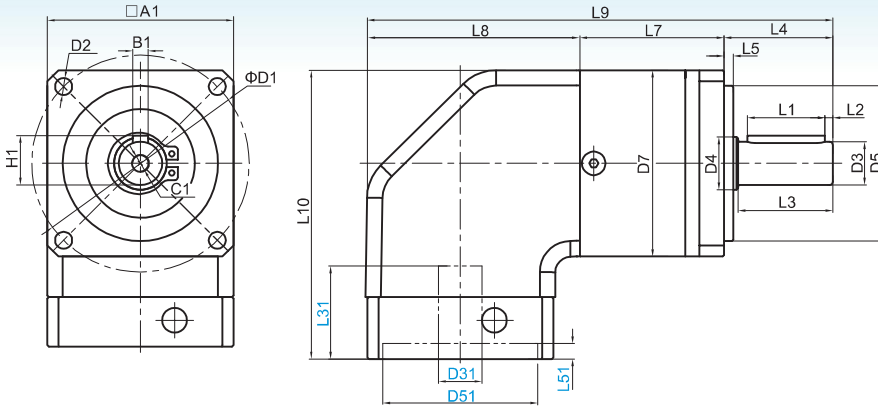

output 輸出端
TFR60~TFR160規格



input 夾緊環輸入端
TFR60~TFR160規格

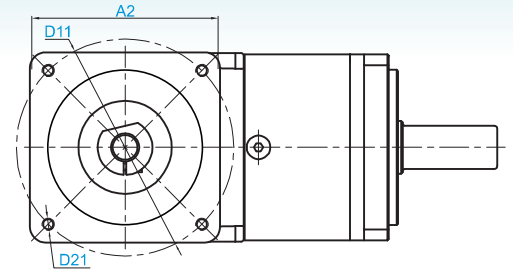

以上藍色字標註可根據客戶電機尺寸更改!

Type Stage 型號 段數		TFR40			TFR60			TFR80			TFR130			TFR160			
		50/100w			200/400w			400/750w			1kw-2kw			3kw-4kw			
		L1	L2	L3	L1	L2	L3	L1	L2	L3	L1	L2	L3	L1	L2	L3	
output 輸出端尺寸	A1 輸出端安裝法蘭	-			60			90			120			175			
	B1 鍵寬	-			5			6			8			12			
	C1 定位孔	-			M5X10			M6X12			M10X22			M12X25			
	H1 鍵高	-			16			22.5			28			43			
	D1 輸出安裝孔分布圓	Φ	-			70			100			130			185		
	D2 輸出安裝孔大小	4X	-			Φ5.5			Φ6.5			Φ8.5			Φ11		
	D3 輸出軸徑	Φh6	-			14			20			25			40		
	D4 輸出軸肩	Φ	-			17			25			35			55		
	D5 定位凸圓直徑	Φh7	-			50			80			110			130		
	D7 外殼直徑		-			60			80			115			162		
	L1 鍵長		-			25			25			40			65		
	L2 鍵至軸末端距離		-			2.5			4			5			8		
	L3 軸至軸肩長度		-			30			36			50			80		
	L4 軸長		-			35			40			55			85		
	L5 定位凸圓厚度		-			3			3			4			5		
	L7 ⁽²⁾ 軀體長		-	-	-	46.5	59.5	72	60	78	95.5	73.7	101.5	129	129	178.5	178.5+
L8 轉角器長度		-			68.5			84.5			120.5			152			
L9 減速機總長度		-	-	-	150	163	175.5	184.5	202.5	220	249.2	277	304.5	368	417.5	417.5+	
L10 轉角器高度		-			93			119			167.5			228			
input 輸入端尺寸 ⁽¹⁾	A2 輸入法蘭	-			60			80			130			175			
	B2 輸入孔鍵寬	-			5			6			8			10			
	H2 輸入孔鍵高	-			16.3			21.8			25.3			38.3			
	D11 電機安裝孔分布圓	-			70			90			145			200			
	D21 輸入安裝螺紋孔	-			M4			M5			M8			M12			
	D31 輸入孔直徑	-			14			19			22			35			
	D51 輸入定位圓直徑	-			50			70			110			114.3			
	L31 輸入孔深度	-			31			41			60			81			
	L51 輸入定位圓厚度	-			10			10			10			10			
	L61 輸入法蘭長度	-			31.5			43.5			66			94			

The above blue word labeling changes according to the customer motor size!

- (1) dimensions refer to the mounted motor-type, the size can be changed
(2) dimensions refer to the frame of the boxes, the size can be changed

以上藍色字標註可根據客戶電機尺寸更改!

- (1) 這些參數都與所配電機的型號有關, 這些尺寸可以有變化
(2) 這些參數與減速機內部結構有關, 這些尺寸可以有變化